

SHARK100-S

Electronic Sub-Meter with Advanced WIFI Ethernet Capability



AGGRESSIVE TECHNOLOGY

NEW

Industry Leading Technology

- High Performance Metering Technology
- 0.2% Accuracy Class
- Revenue Certifiable Test Pulse with KYZ Output
- IEEE 802.11 Wireless Ethernet Capability
- 10 Base T Ethernet - RJ45
- Modbus RS485 or Modbus TCP
- For Commercial Building, Industrial and Shopping Mall Applications



Wireless Sub-Meter

Feature Summary

- 0.2% Class Revenue Certifiable Energy and Demand Submeter
- Meets ANSI C12.20 (0.2%) and IEC 687 (0.2%) Classes
- Multifunction Measurement Capability
- Power Quality Measurements
- 3 Line 0.56" Bright Red LED Display
- % of Load Bar
- Ethernet and Wireless Ethernet
- Serial RS485 Communication
- Modbus RTU and Modbus TCP (Over Ethernet)
- Direct Interface with Most Building Management Systems



Accurate Metering, Leading Communication Technology

Applications

- Universities
- Industrial Submetering
- Commercial Buildings
- Government Facilities
- Shopping Malls

Introduction

Electro Industries introduces one of the most advanced electrical submeters. This high performance product is designed to measure revenue grade electrical energy usage and communicate back that information using modern communication mediums. The unit supports RS485, RJ45 Ethernet or IEEE 802.11 Wi-Fi® Ethernet connections. This allows it to be placed anywhere within a facility and have it communicate back to central software quickly and automatically.

The unit uses standard 5 or 1 amp CTs (either split or donut). It surface mounts to any wall and is easily programmed in minutes. The unit is designed specifically to be a low cost, highly accurate submeter with advanced communication and easy installation.



Secure Wireless Submetering

V-Switch, Measurement Upgrade Packs

The Shark 100-S is equipped with EIG's exclusive V-Switch® Technology. V-Switch® is a virtual firmware-based switch that allows you to enable meter features through communication, even after installation. Using V-Switches, you can purchase what you require now and field upgrade functionality as needed. This allows you to optimize your metering investment. Begin with a simple energy billing submeter and upgrade it to full functioning energy billing meter with power quality and alarm measurements.

Available V-Switches:

- V-Switch 3 – Volts, Amps, kW, kVAR, PF, kVA, Freq. kWh, kVAh, kVARh
- V-Switch 4 – Volts, Amps, kW, kVAR, PF, kVA, Freq. kWh, kVAh, kVARh, %THD Monitoring and Limit Exceeded Alarms

Accuracy

Measured Parameters	Accuracy % of Reading	Display Range
Voltage L-N	0.1%	0-9999 Scalable V or kV
Voltage L-L	0.1%	0-9999 V or kV Scalable
Current	0.1%	0-9999 Amps or kAmps
+/- Watts	0.2%	0-9999 Watts, kWatts, MWatts
+/-Wh	0.2%	5 to 8 Digits Programmable
+/-VARs	0.2%	0-9999 VARs, kVARs, MVARs
+/-VARh	0.2%	5 to 8 Digits Programmable
VA	0.2%	0-9999 VA, kVA, MVA
VAh	0.2%	5 to 8 Digits Programmable
PF	0.2%	+/- 0.5 to 1.0
Frequency	0.01 Hz	45 to 65 Hz
%THD	2.0%	0 to 100%
Neutral Current	2.0%	0 to 9999 Amps or kAmps
% Load Bar	1-120%	10 Digit Resolution Scalable

Note: Typical results are more accurate.

Traceable Watt-Hour Test Pulse for Accuracy Certification

To be certified for revenue metering, power providers and utility companies need to know that the billing energy meter will perform to the stated accuracy. To verify the meter's performance and calibration, power providers use field test standards to ensure that the unit's energy measurements are correct. Since Shark 100-S is a traceable revenue meter, it contains a utility grade test pulse allowing power providers to verify and confirm that the meter is performing to its rated accuracy. This is an essential feature required of all billing grade meters.

Generate Cost Allocation

Using Energy Manager HMI, you can data trend energy usage to provide utility bills for usage and demand. You can also customize rate structures and aggregate multiple meters for billing.

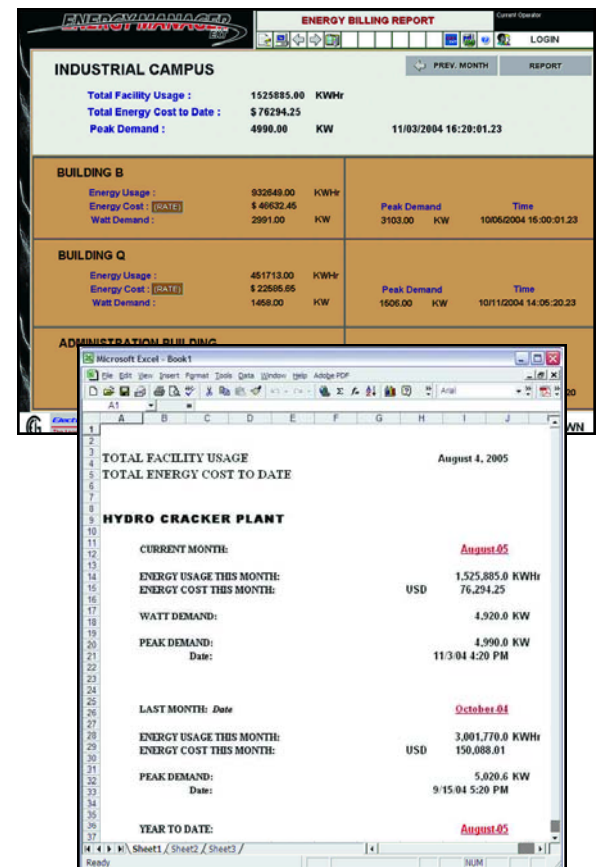

Utility Peak Demand Metering

The Shark 100-S provides user-configured Block Window or Rolling Window Demand. This allows you to set up a particular utility demand profile. Block Window Demand is demand used over a fixed user-configured demand period (usually 5, 15 or 30 minutes). Rolling Window Demand is a fixed window demand that moves for a user specified sub-interval period. An example would be a 15-minute demand using 3 subintervals,

providing a new demand reading every 5 minutes based on the last 15 minutes. Readings for kW, kVAR, kVA and PF are calculated using utility demand structures. All other parameters offer max and min capability over the user-selectable averaging period. Voltage provides an instantaneous max and min reading, displaying the highest surge and lowest sag seen by the meter.

Advanced Communication Capability with IrDA Interface

The unit provides a wide range of outputs. The unit can be equipped with any of the following communication mediums.

Standard RS485 Communication

Standard communication includes an RS485 output speaking Modbus protocol. This allows the units to be connected to any serial RS485 bus using the Modbus interface. The unit will communicate easily with most building automation or other software systems.

Wi-Fi® or Land Based Ethernet

The unit has an option to connect a WIFI or RJ45 connection. This allows the Shark 100-S to be used on standard WIFI base stations. The unit is assigned an IP address and it communicates Modbus protocol over Ethernet TCP/IP.

IrDA Port for PDA Read

Using the infrared port, the Shark 100-S can view and capture data using either a laptop or a pocket PC based PDA.



KYZ Pulse

In applications in which a pulse is needed, the unit also provides a KYZ output which pulses proportional to the amount of energy consumed. This is used for pulse counting applications or for building management systems where serial or Ethernet protocol is not available.

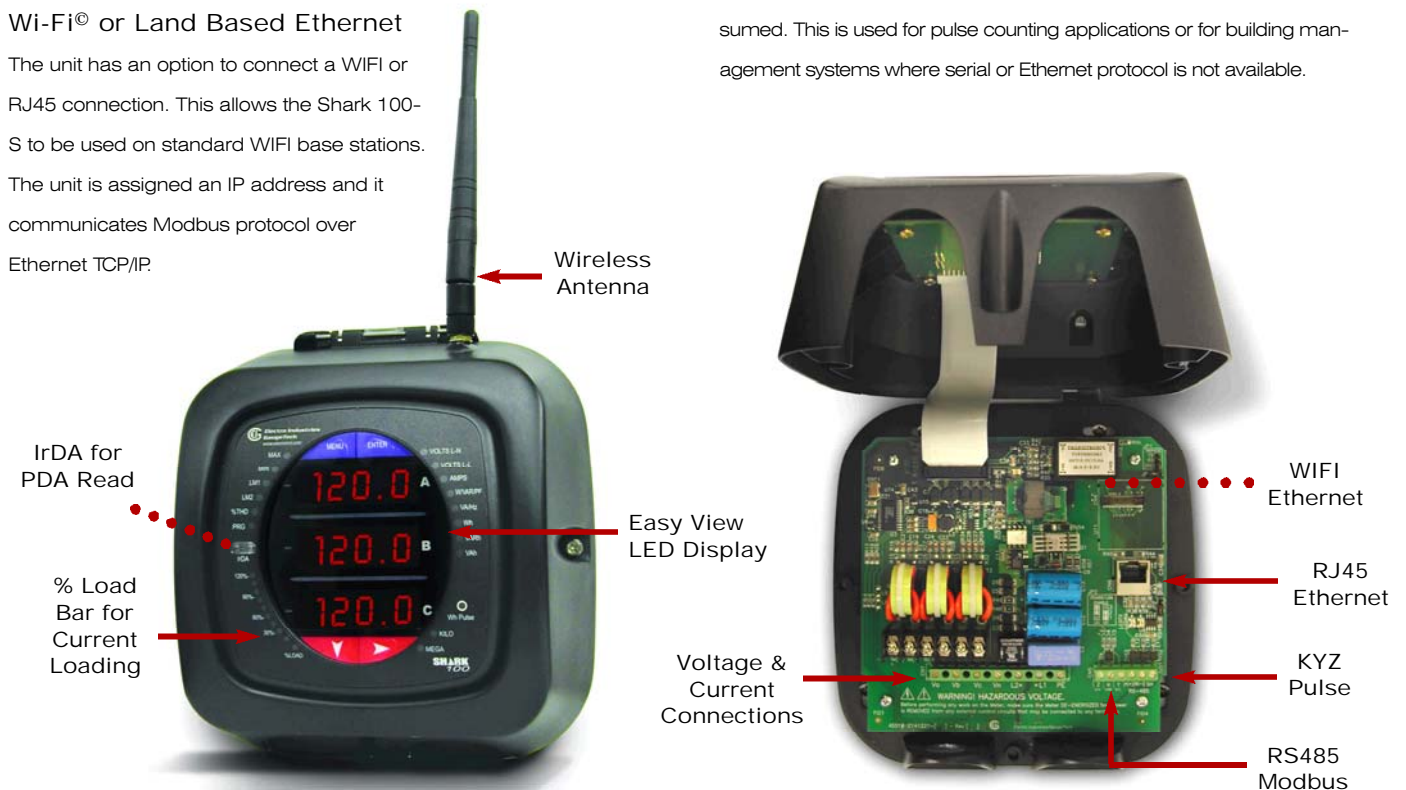

Wireless Ethernet Provides a Simple Wireless Architecture

This unit is designed to harness the latest technology by providing a simple, over the counter wireless architecture that is easy to integrate and is reliable. This unit uniquely can be used over any existing wireless or wired Ethernet infrastructure. Just install the unit, plug in the IP address for each unit and the device is automatically on your LAN wirelessly. Simply extend the network by adding WIFI access points.

Benefits of Wireless Ethernet over Dedicated 900 MHz Spread Spectrum

- Standard Infrastructure (No Dedicated Hardware)
- Low Cost to Deploy and Expand
- Superior Speed Over Dedicated Wireless Networks
- Significantly Easier to Configure and Maintain
- Secure Connection - 128 bit Encryption
- Standard Modbus TCP Data Stream
- Can be Easily Integrated through Internet

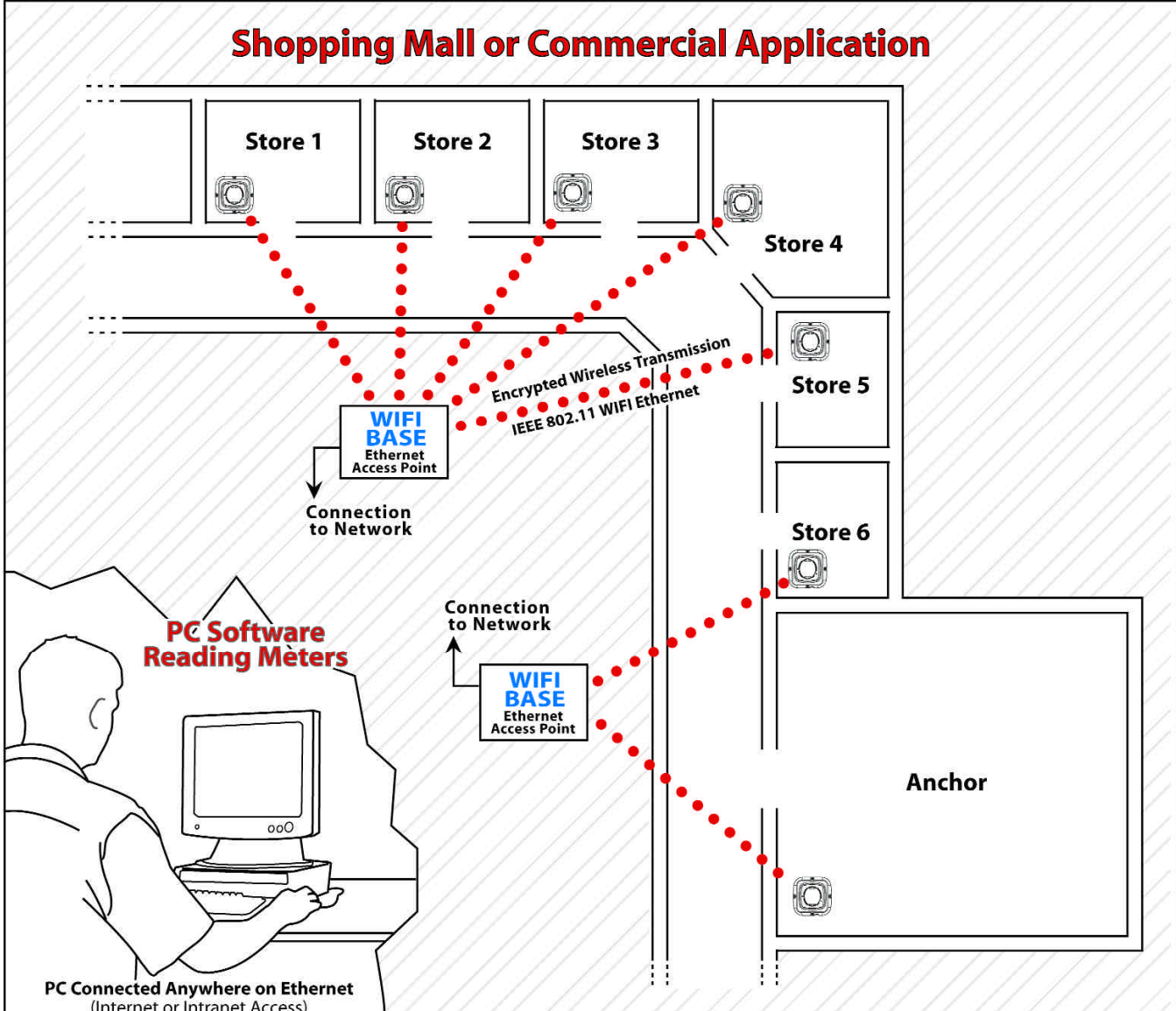

Harnessing the Power of Ethernet for Fast Reliable Communication

Dimensional Drawings

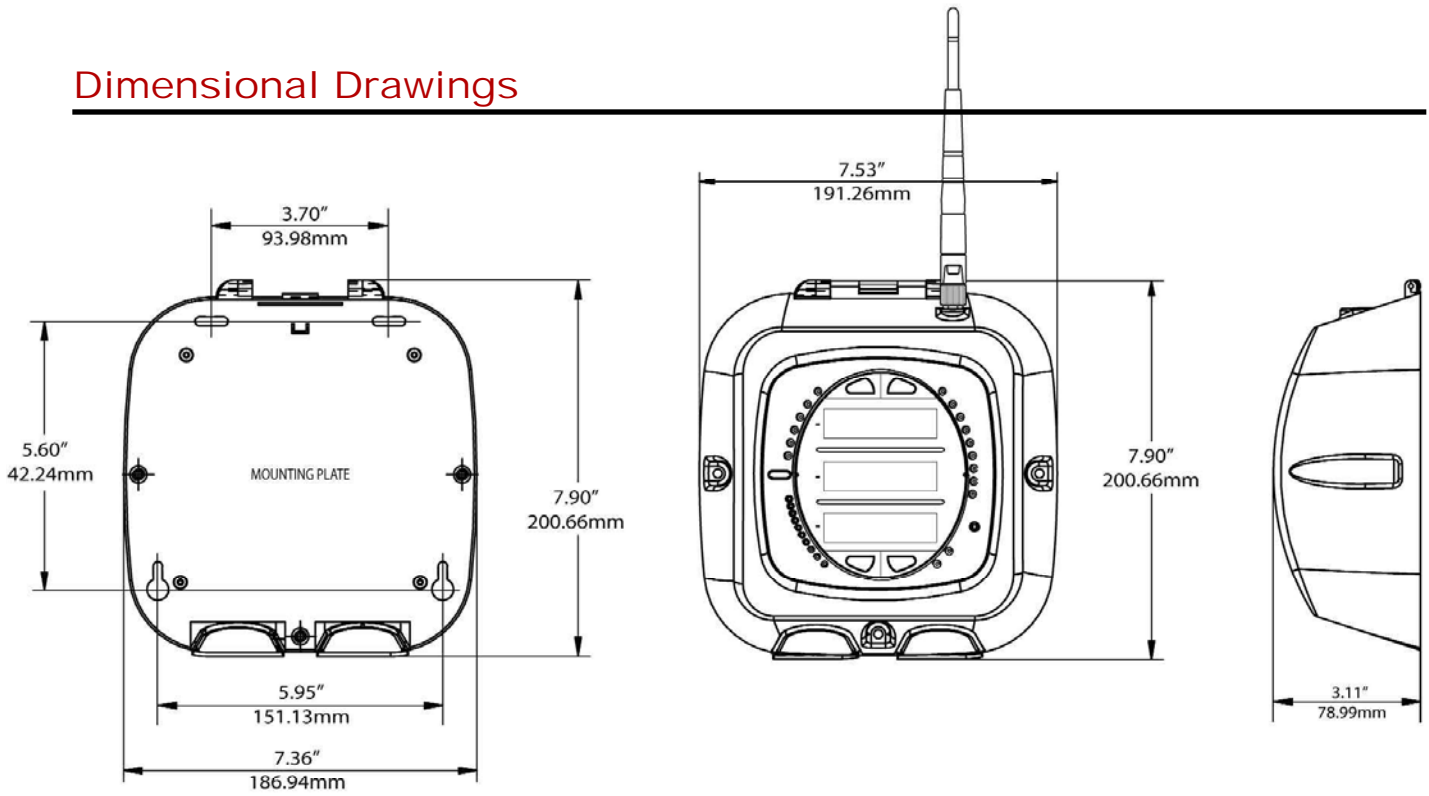

Installation

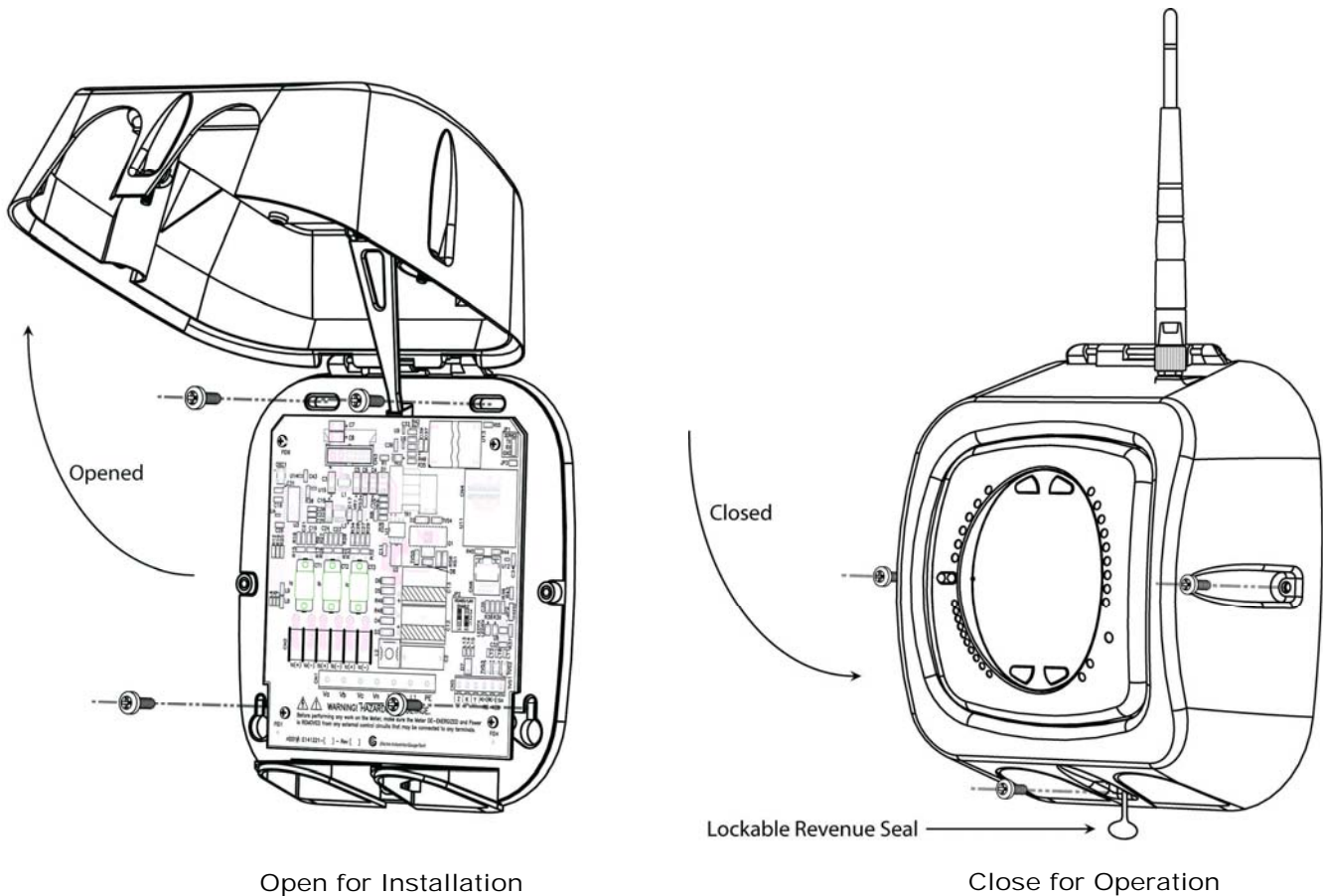

Wiring Diagrams

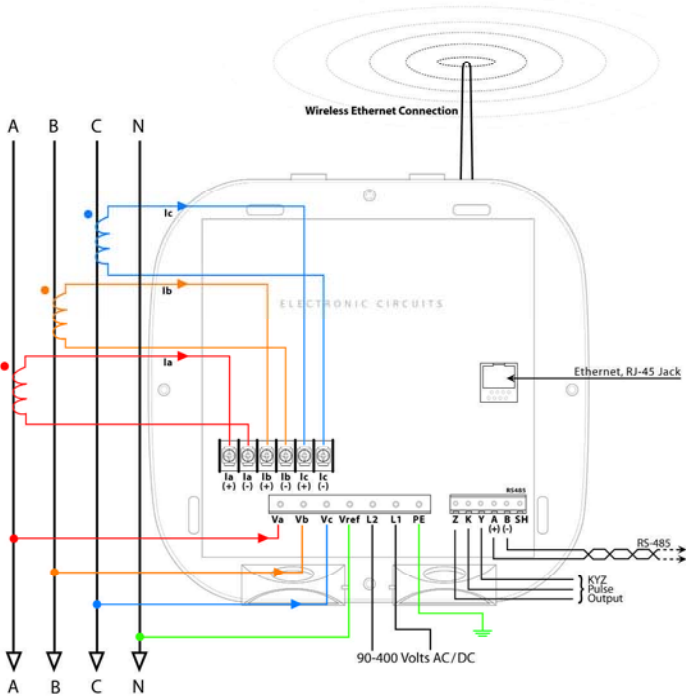

3 Phase 4 Wire WYE Direct

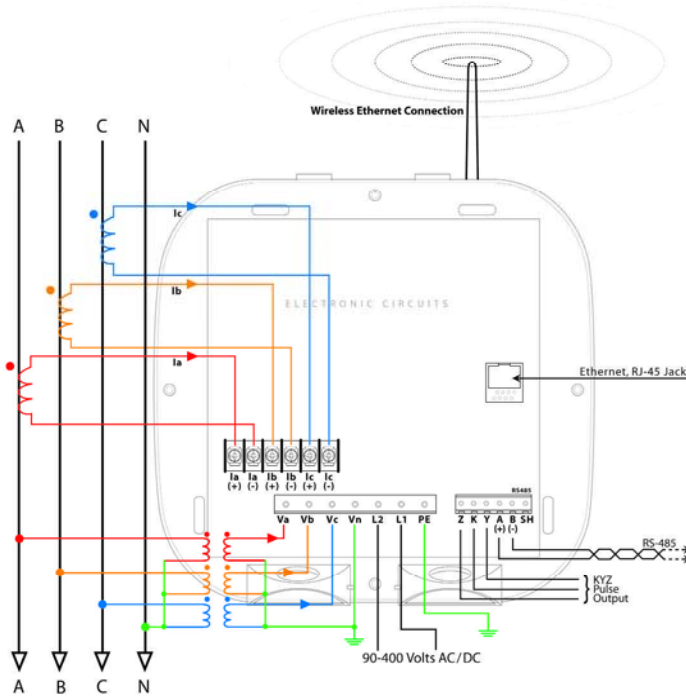

3 Phase 4 Wire WYE with PTS

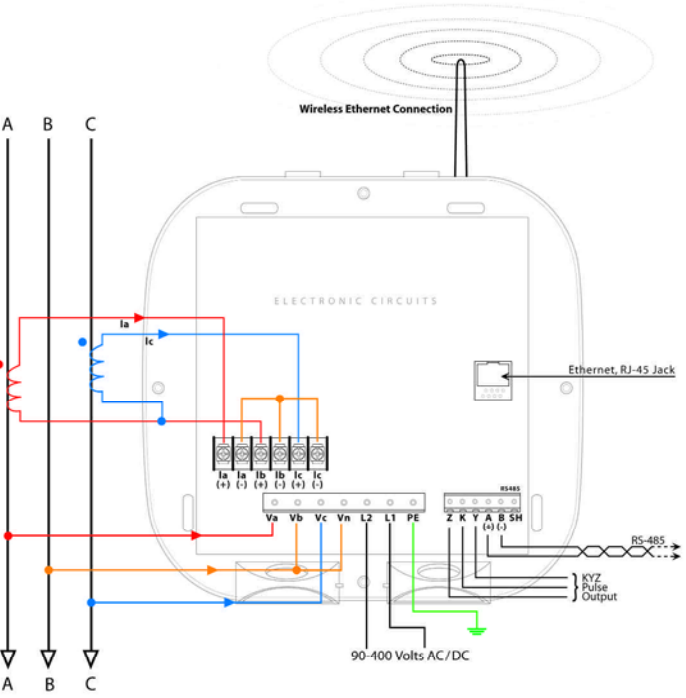

3 Phase 3 Wire Delta Direct

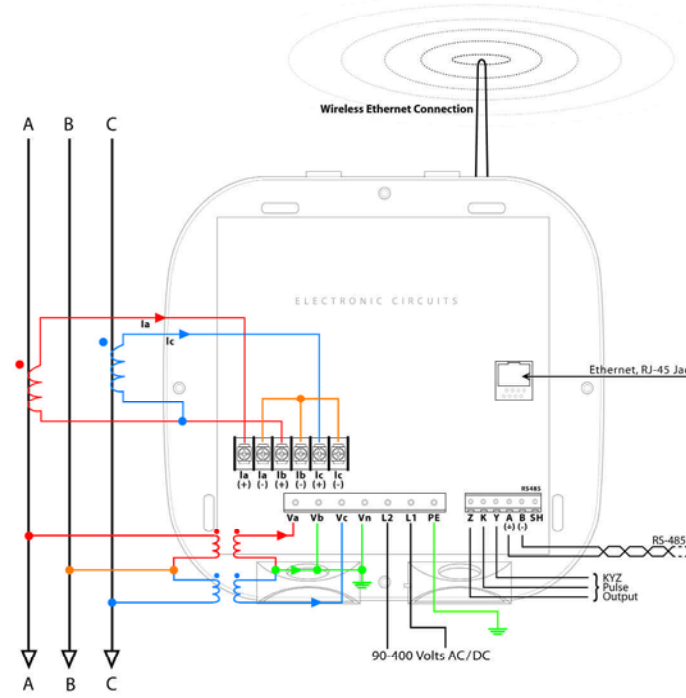

3 Phase 3 Wire Delta with PTS

Specifications

Voltage Inputs

- 0-416 Volts Line To Neutral, 0-721 Volts Line to Line
- Universal Voltage Input
- Input Withstand Capability – Meets IEEE C37.90.1 (Surge Withstand Capability)
- Programmable Voltage Range to Any PT ratio
- Supports: 3 Element WYE, 2.5 Element WYE, 2 Element Delta, 4 Wire Delta Systems
- Burden: 0.36VA per phase Max at 600V, 0.014VA at 120 Volts

Current Inputs

- Class 10: (0 to 11) A, 5 Amp Nominal
- Class 2: (0 to 2) A, 1A Nominal Secondary
- Programmable Current to Any CT Ratio
- Burden 0.005VA per phase

- Max at 11Amps
- 5mA Pickup Current

Isolation

All Inputs and Outputs are galvanically isolated to 2500 Volts AC.

Environmental Rating

- Storage: (-40 to +85)° C
- Operating: (-30 to +70)° C
- Humidity: to 95% RH
- Non-Condensing

Sensing Method

- True RMS
- Sampling at 400+ Samples per Cycle on all channels measured readings simultaneously
- Harmonic %THD (% of Total Harmonic Distortion)

Update Rate

- Watts, VAR and VA-100msec
- All other parameters-1second

Power Supply

- (90 to 400) Volts AC and (100 to 370) Volts DC. Universal AC/DC Supply
- Burden: 16VA max.

Communication Format

- 2 Com Ports
- RS485 Port (Through Mounting Plate)
- IrDA (Through Faceplate)
- Protocol Modbus RTU, Modbus ASCII
- Com Port Baud Rate: (9600 to 57,600)
- Com Port Address: 0-247
- 8 Bit, No parity
- Modbus RTU or ASCII Protocols

Ethernet

- 802.11b Wireless
- 10 Base T Ethernet (RJ45)
- Wireless Security 128 Bit
- Modbus TCP Protocol

Dimensions and Shipping

- Weight: 4 lbs

Meter Accuracy

- See page 3

Compliance:

- IEC 687 (0.2% Accuracy)
- ANSI C12.20 (0.2% Accuracy)
- ANSI (IEEE) C37.90.1 Surge Withstand
- ANSI C62.41 – Burst
- IEC1000-4-2 – ESD
- IEC1000-4-3 – Radiated Immunity
- IEC 1000-4-4 – Fast Transient
- IEC 1000-4-5 – Surge Immunity

Ordering Information

To order, please fill out ordering guide:

	Model	Frequency	Current Class	V-Switch Pack	Communication Format
Option Numbers:	-	-	-	-	-
Example:	Shark100-S	-60	-10	-V3	-485
	Shark100-S	-50 50 Hz System	-10 5 Amp Secondary	-V3 Default with Energy Counters	-485 RS485
		-60 60 Hz System	-2 1 Amp Secondary	-V4 Above with Harmonics and Limits	-WIFI Wireless and LAN Based Ethernet

Additional Accessories

Communication Converters

CAB 6490 – USB to IrDA Adapter for Programming

Unicom 2500 – RS485 to RS232 Converter

Unicom 2500-F – RS485 to RS232 to Fiber Optic Converter

Modem Manager, Model #, MM1 – RS485 to RS232 Converter for Modem Communication

Compliance Documents

Certificate of Calibration, Part #: CCal – This provides Certificate of Calibration with NIST traceable Test Data.

Current Transformer Kits

CT200K – 200/5 Ratio .94" Window 3 CTs

CT400K – 400/5 Ratio, 1.25" Window, 3 CTs

CT800K – 800/5 Ratio, 2.06" Window, 3 CTs

CT2000K – 2000/5 Ratio, 3.00" Window, 3 CTs

CT Specifications:

Frequency: 50 to 400Hz; Insulation: 600 Volts, 10kV BIL
Flexible Leads: UL 1015 105°C, CSA Approved, 24" Long, #16AWG

Software Option Numbers

COMEXT3.1C – CommunicatorEXT 3.0 for Windows® (Single Lic)

COMEXT3.MC – CommunicatorEXT 3.0 for Windows® (Multi Lic)

* Consult factory application engineer for additional transformer ratios, types or window sizes.



Electro Industries/GaugeTech

1800 Shames Drive • Westbury, NY 11590

1-877-EIMETER (1-877-346-3837) • E-Mail: sales@electroind.com

Tel: 516-334-0870 • Web Site: www.electroind.com • Fax: 516-338-4741

E145722 061005 REV A