

ISO 9001:2008 Certified

CONZERV[®]
Smart Energy Management

EM6400 DigitAN™ v03.02 Multifunction Load Manager

1 Measure

• 2 Detect •

3 Control



Applicable for models
All models - v03.02.12
EM 6400, EM 6459, EM 6434 - v03.02.02
EM 6436, EM 6433 - v03.02.11

Optimum Energy Products Inc.
#333 11979 40 St. SE
Calgary, AB T2Z4M3
Canada

Phone 403 256 3636
Toll Free 877 766 5412
Fax 403 256 3431

www.PowerMeterStore.com

CONTENTS

1. GENERAL	5
1.1. CUSTOMER SERVICE AND SUPPORT	5
1.2. PRODUCT WARRANTY	5
1.3. LIMITATION OF WARRANTY	5
1.4. STATEMENT OF CALIBRATION	5
1.5. DISCLAIMER	5
2. OVERVIEW	7
2.1. PHYSICAL DESCRIPTION	8
2.2. FRONT PANEL	8
2.2.1. <i>The Indicators</i>	9
2.2.2. <i>The Keys</i>	9
2.2.3. <i>Here's an example to try:</i>	11
3. QUICK START GUIDE.....	12
3.1. EM 6400 TECHNICAL SPECS.....	12
3.1.1. <i>Measurements with EM 6400 DigitAN series</i>	13
3.1.1.1. <i>Accuracy</i>	14
3.1.2. <i>Auxiliary Power Supply</i>	14
3.1.3. <i>Front Panel Display</i>	14
3.1.4. <i>Installation & Input Ratings</i>	14
3.1.5. <i>Environmental Conditions</i>	15
3.1.6. <i>Safety Construction</i>	15
3.1.7. <i>Dimensions & Shipping</i>	15
3.2. DISPLAY PARAMETERS WITH THE EM 6400 DIGITAN METERS	16
3.3. KEYPAD OPERATION	17
3.3.1. <i>Auto-Scroll</i>	22
3.3.2. <i>Default Display (View) Page – Only in v03.02.11 & v03.02.12 EM6436 & EM6433</i>	22
3.3.3. <i>TURBO key</i>	22
3.4. PROG MENU – SETUP	23
3.4.1. <i>Enter PROG Menu in Edit Mode</i>	23
3.4.2. <i>Enter PROG Menu in View (read – only) mode</i>	24
3.4.3. <i>Enter PROG Menu on Power ON</i>	24
4. ENTIRE LIST OF PROG MENU – SETUP PARAMETERS	25
4.1. EDIT SET PARAMETERS IN PROG MENU	26
4.1.1. <i>Edit and accept setup</i>	26
4.1.2. <i>To save the new value to setup</i>	26
4.1.3. <i>Clear INTG and MD</i>	27
4.1.4. <i>Energy Integrator</i>	28
4.1.4.1. <i>Integrator Overflow</i>	28
4.2. SUMMARY	28
5. AC POWER MEASUREMENT	29
5.1. THREE-PHASE SYSTEMS	29

5.2. CONSUMPTION & POOR PF	30
5.3. “3D” kVA MEASUREMENT	30
6. MECHANICAL INSTALLATION.....	31
6.1. INSTALLATION PROCEDURE.....	33
6.1.1. Panel Mounting for New Installations	33
6.1.1.1. Location and Mounting considerations.....	33
6.1.1.2. Usage	33
6.1.1.3. Panel Considerations and Environment.....	33
6.1.1.4. Viewing.....	34
6.1.1.5. Mounting.....	34
7. ELECTRICAL INSTALLATION	35
7.1. AUXILIARY (CONTROL) POWER SUPPLY	36
7.2. PTS AND CTS.....	36
7.2.1. PT, CT Wiring.....	36
7.3. VOLTAGE SIGNAL CONNECTIONS	37
7.3.1. PT Connections	37
7.3.2. Selecting the Voltage Fuses.....	37
7.4. CURRENT SIGNAL CONNECTIONS.....	37
7.4.1. CT Connections.....	38
7.4.2. CT Polarity	38
7.4.3. CT Connection Reversal.....	39
7.5. SETUP – SYSTEM TYPE	39
7.6. PHASE LABELS.....	39
7.7. CONNECTION DIAGRAMS.....	39
7.7.1. EM 6400 Rear Panel.....	39
7.7.2. Three Phase 3 Wire Delta	40
7.7.3. Three Phase 4 Wire Star (Wye)	41
7.7.4. Single phase connection	42
8. COMMUNICATION INSTALLATION	43
8.1. RS-485.....	43
8.2. REPEATERS	44
8.3. FACTORY SETTINGS	45
8.4. MODBUS REGISTERS	45
8.4.1. Parameters not available on Display.....	46
9. APPENDIX	46
10. KEY FACTOR FOR SUCCESS	48
11. FAQ’S.....	55
11.1. NOMENCLATURE.....	55
11.2. INSTALLATION.....	56
11.3. DISPLAY INDICATIONS.....	57
11.4. SETUP	59
11.5. SIM (SIMULATION) MODE.....	61
11.6. AUTO SCROLL	61
11.7. TURBO PARAMETERS (FAVOURITE PAGES)	62
11.8. DEFAULT DISPLAY PAGE	62

11.9. INTEGRATORS	63
11.10. FEATURES	64
11.11. COMMUNICATION	66
11.12. GENERAL	67

1. GENERAL

1.1. Customer Service and Support

Questions? Difficulties? We're here to help. Customer service and support is available via email at support@conzerv.com. Please include the model, serial number and a description with which we can re-create the problem at our Support Centre. You can shorten this time by also including necessary settings, the wiring diagram and the particular readings, which uniquely identify the problem.

Toll free phone support is available in some countries. For the latest phone number list please visit www.conzerv.com

1.2. Product Warranty

CONZERV warrants all products to be free from defects in material, workmanship and title and will be of the kind and quality specified in CONZERV's written description in the manual. The foregoing shall apply only to failures to meet said warranties, which appear within one year from the date of shipping. During the warranty period, CONZERV will, at its option, either repair or replace any product that proves to be defective. Please see the LIMITED WARRANTY CERTIFICATE provided with the product for further details.

1.3. Limitation of Warranty

This warranty does not apply to defects resulting from unauthorized modification, misuse or use for any reason other than electrical power monitoring.

OUR PRODUCTS ARE NOT TO BE USED FOR PRIMARY OVER-CURRENT PROTECTION. ANY PROTECTION FEATURE IN OUR PRODUCTS IS TO BE USED FOR ALARM OR SECONDARY PROTECTION ONLY.

THIS WARRANTY IS IN LIEU OF ALL OTHER WARRANTIES, EXPRESSED OR IMPLIED, INCLUDING ANY IMPLIED WARRANTY OF MERCHANTABILITY OR FITNESS FOR A PARTICULAR PURPOSE. CONZERV SHALL NOT BE LIABLE FOR ANY PENAL, INDIRECT, SPECIAL OR CONSEQUENTIAL DAMAGES ARISING FROM ANY AUTHORIZED OR UNAUTHORIZED USE OF ANY CONZERV PRODUCT. LIABILITY SHALL BE LIMITED TO THE ORIGINAL COST OF THE PRODUCT SOLD.

1.4. Statement of Calibration

Our instruments are inspected and tested in accordance with specifications published by an independent testing facility. The accuracy and calibration of our instruments are traceable to the National Institute of Standards and Technology through equipment that is calibrated at planned intervals by comparison to certified standards.

1.5. Disclaimer

The information presented in this publication has been carefully checked for reliability; however, no responsibility is assumed for inaccuracies. The information contained in this document is subject to change without notice.

Blank pages for notes

2.OVERVIEW

The EM 6400 DigitAN are digital power meters that offer comprehensive three-phase electrical instrumentation and load management facilities in a compact and rugged package.

To get the best out of your investment, we suggest that you take a few moments to review this manual. This chapter contains the main operating instructions. The remaining chapters explain the installation and setup steps before the meter is ready for use.

The EM 6400 DigitAN is a universal meter. Before use, please program the SYS (measurement system configuration), PT and CT ratios through the front panel keys. Otherwise, it will read your system incorrectly. Other settings such as communication parameters must also be programmed as needed.

CONZERV stands behind your EM 6400 DigitAN meter with complete User Support and Service. If the need arises, please do not hesitate to contact us at info@powermeterstore.com.



Figure 2.1: The EM6400 DigitAN - multi-function load manager

2.1. Physical Description

FRONT: The front panel has 3 rows of 4 digits / characters each, with auto scaling “K” kilo, “M” Mega and “--” minus indications. The “kilo” and “Mega” indications lit together show Giga readings. The Load bar graph to the right of the display gives the indication of consumption in terms of the % A Load with respect to the FS selected. Five smart-keys make navigating the parameters very quick and intuitive for viewing data and configuring (Setup) the EM 6400.

REAR: The voltage and current terminals and the communication port are located on the back of the meter. **CAUTION: These contain hazardous voltages during operation and must be operated only by qualified and authorized technicians.**

2.2. Front Panel

The front panel contains the following indicators and controls:

- Three rows of alphanumeric displays, 4 digits each that display three RMS parameters simultaneously, or one energy parameter. The displayed readings update every second.
- For each row: Kilo, Mega (Kilo + Mega = Giga) indicator and a Negative (-) indicator.
- Load bar, which gives a unique analog indication of % loading (% FS CT Pri).
- Five keys to scroll through the display page.

The EM 6400 solves the problem of tiny cluttered indicators by prominently displaying the parameter name right on the large, alphanumeric readouts. For the first time in a panel meter, the parameter name is as clearly readable as the value. The name will be displayed for 2 seconds as well as each time you press a key and then the Value for 8 seconds. This method also allows programmable phase soft-Labels in the EM 6400 DigitAN meters. You can choose from 123 (Factory setting), ABC, RYB, PQR or RST.



Figure 2.2: The EM 6400 front panel with display and keypad

2.2.1.The Indicators

Table 2.1: Kilo, Mega and Negative Indicators

M	<p>Mega: When lit, indicates that the reading is in Mega, (10^6). 10,000 K is shown as 10.00 M. 1.0 M is displayed as 1000 K.</p> <p>When Kilo and Mega are both glowing, the reading is in Giga (10^9). 10,000 M is shown as 10.00 G. 1.0 G is shown as 1000 M.</p>
-	<p>Neg: - When lit, indicates that the reading is negative Per IEEE 100 and industry standard practice by meter-men, the following are Negative:</p> <ul style="list-style-type: none"> • When the flow of watts is forward: Capacitive (Leading) VARs & PF are negative. • When the flow of watts is reverse: Inductive (Lagging) VARs & PF and Watts are negative.
K	<p>Kilo: When lit, indicates that the reading is in Kilo (10^3). 10,000 is displayed as 10.00 K. 1.0 K is shown as 1000.</p>

Table 2.2: Giga, Mega (M), Kilo (K) & Decimal Point Scaling

RMS Reading	Indicator
Less than 0.001	K, M OFF, displays “0.000”
Less then 9999	K, M OFF
Above 9999	K ON, M OFF
Above 9999 k	M ON, K OFF
Above 9999 M	Giga (K + M indicators ON)
Upto 9999G	Giga
Above 9999G	Display shows “Hi” for positive numbers, “Lo” for negative numbers



RMS readings are four digits. Energy readings have eight digits, including four additional fractional digits. The maximum number the meter handles is 9,999 G for RMS and energy values.



This means that the energy readings of the meter will overflow at 3 values of kWh or kVAh (selectable through PROG menu - Setup) depending upon the PT and CT ratios programmed. See Table 3.4 “[Integrator Overflow Value](#)”.

2.2.2.The Keys

Operating the meter is easy using the five smart keys to navigate through the [Keypad Operations Table](#). The display pages “expand” as you go right, much like the directory or explorer “tree” displayed on any computer. **The display shows where you’re headed.**

Table 2.3: The Key pad operation table

	<p>Right Key:</p> <ul style="list-style-type: none"> • Go forward into sub-parameter pages. • During Edit Setup values, select next (right side) digit.
	<p>Left Key:</p> <ul style="list-style-type: none"> • The Opposite of the right key. • Go back towards to the main parameter pages. Going left past “PROG” requires code entry to enter PROG menu (Setup and Clear) • During Edit Setup, selects previous (left side) digit • Exits from Edit mode, back to the PROG menu - Setup.

	<p>Up Key:</p> <ul style="list-style-type: none"> • Scroll up through display pages at the same level, within the same function. • Continuous pressing for 3 seconds initiates limited auto-scroll (within the same function). Press any key to return to manual scrolling. • While editing, increases the value of the blinking digit during edit. Typically while changing the meter setup settings.
	<p>Down Key:</p> <ul style="list-style-type: none"> • The opposite of the up key. Scroll down through other display pages at the same level, through all functions. • Continuous pressing for 3 seconds initiates the full auto-scroll mode, through all functions. Press any key to return to manual scrolling. • While editing, decreases the value of the blinking digit during edit.
	<p>TURBO Key:</p> <ul style="list-style-type: none"> • The TURBO key scrolls through the following pages: RMS (home page), VLL, A, PF VLN, A, F VA, W, VAR W, VAR, PF PF1, PF2, PF3, V%1,V%2,V%3 A%1, A%2, A%3 VA.d, R.d, T.R, MD, HR VAh Wh R.VAh R.Wh t.VAh t.Wh. This gives simple one-touch access to the most commonly used parameters, even for unskilled operators. “One Touch” does not operate in the PROG menu – Setup. • Note EM6436, TURBO key scrolls through the following pages: RMS (home page), VLL, A, PF VLN, A, F A, W, PF PF1, PF2, PF3 Wh and Run hours • EM 6433, TURBO key scrolls through the following pages: RMS (home page), A, W Wh and Run hours • If you’re lost, the TURBO key is a quick way to get back to the RMS home page. • Continuous pressing for 3 seconds initiates auto-scrolling through the above TURBO pages. • During the power up, if the TURBO key is pressed, meter will go in to PROG menu - Setup. This is the simplest way to enter in to the setup.

The parameter name is displayed every 8th second for 2 seconds, as well as the first time you press a key. **At this point press the next key immediately to scroll to the next page you want to see. If you are not sure which page you’re watching, one press of any key will immediately identify the name. Pressing the key again immediately takes you to the next page.**

The meter menus and displays are organized as below. Navigating with the EM 6400 is very easy and intuitive. For full details, see the [Keypad Operations Table](#) and the Meter Function Map. The left-most column (RUN, CLR, SET) constitutes the “PROG menu”. Press the key in the direction you want to go. **Display shows where you’re headed.** Press the key that takes you in the desired direction.

2.2.3. Here's an example to try:

Table 2.4: Menu and Display Map

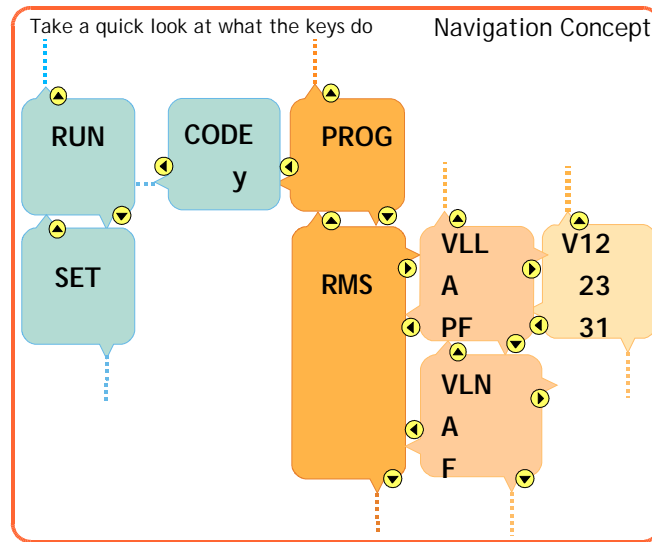

Let us take an example to understand the actions of the front panel keys in the RUN menu. This example will explain how you can navigate from the 'RMS' page to the 'VLN A F' page, back to 'RMS' and then to 'PROG' in EM 6400

Step1: From the RMS page use the RIGHT key (▶) The display shows 'VLL A PF'.

The RIGHT key can be used to go forward into sub-parameter pages.

Step2: Now press the DOWN key (▼).

You can scroll down through other pages at the same level using the DOWN key. The display shows 'VLN A F'. Congratulations you have successfully navigated from 'RMS' to 'VLN'.

Step3: To return to 'RMS' press the LEFT key (◀). The display shows 'RMS'.

Using the left key you can go back towards to the main parameter pages from the subparameter pages.

Going Left past 'PROG' requires CODE entry to enter PROG menu (Setup and Clear).

Step4: Now press UP key (▲).

The display shows 'PROG'. Congratulations you have successfully navigated to the PROG page.

Using the UP key you can scroll up through all the display pages at the same level and within the same function.

3. Quick Start Guide

3.1.EM 6400 Technical Specs

The EM 6400 DigitAN series is a high-accuracy, low cost, ultra-compact, power and energy meter that offers ISO 9001 quality, accuracy and functional flexibility and MODBUS RTU communications capability. The standard unit flush-mounts in a DIN 96 cutout and conforms to UL and CE safety requirements.

The EM 6400 DigitAN series is designed for retrofit application such as replacement of existing analog meters and is also usable as a stand-alone meter in custom panels, PDUs, switchboards, switchgear, UPS's, generator sets, MCCs systems etc.

The EM 6400 DigitAN series provides easy communication to PLCs, DCS, BMS and other systems through the use of Modbus RTU communications on RS 485, with isolation voltage minimum 2kV for 1 minute, from other circuits.

The EM 6400 DigitAN series of meters are configurable & user programmable through the front panel.

Measures true RMS electrical parameters. 1 Second update

Wh accuracy: Class 1.0 as per IEC 62052-11 and 62053-21, class 0.5S is optional as per IEC 62052-11 and 62053-22 and ANSI C12.20.

Impulse: 6 kV IEC 60060 1.2 μ S/50 μ S.

Surge withstand as per IEEE C37.90.1: 2002 (ANSI), Burst as per IEEE 62.41: 1991 (ANSI)

Fast Transient: > 4kV IEC 61000-4-4 Level 4

ESD IEC 61000-4-2

Emission meets CISPR 22

Power 4 Quadrants, Energy 2 Quadrant. Provides 3D power computation for kVA

Color -coded load bar graph for the quick analog estimation of consumption from a distance without touching any keys.

Patented alphanumeric display for easy readability.

3.1.1. Measurements with EM 6400 DigitAN series

The EM 6400 DigitAN can measure, locally display and remotely transfer over MODBUS RTU, the following electrical parameters over the input range with an accuracy of Class 1.0 or better for Volts and Amps, Power and Energy functions, Class 0.5 is optional:

Table 2.4a: Measurements with EM 6400 DigitAN series meters

Parameters	EM 6459	EM 6433	EM 6434	EM 6436	EM 6400
True RMS voltage phase to neutral and 3phase average	•			•	•
True RMS voltage phase to phase and 3phase average	•			•	•
True RMS current per phase and 3phase average	•	•		•	•
Frequency	•			•	•
Power Factor	•		•	•	•
Real Power and Energy		•	•	•	•
Reactive Power and Energy			•		•
Apparent Power and Energy			•		•
OLD Real Power and Energy		•	•	•	•
OLD Reactive Power and Energy			•		•
OLD Apparent Power and Energy			•		•
Import/Export Parameters (Ordering Option) - VAh, Wh, VARh (Ind and Cap), Run hours, On hours, Interruptions					•
Demand Parameters (Ordering Option) (W/VA Demand, Rising Demand, Maximum Demand, Maximum Demand Time, Time remaining)					•
Total Harmonic Distortion (Ordering Option) (V1%, V2%, V3%, A1%, A2%, A3%)					•

Note: This document is applicable for:

All models - v03.02.12.

EM6400, EM6459, EM 6434 – v03.02.02.

EM 6436, EM 6433 – v03.02.11.

The EM 6400 provides all single phase (per-phase) Real, Apparent, Reactive Power and Power Factor values. Positive (Inductive) and Negative (Capacitive) Reactive Energy is separately accumulated for Lead / Lag analysis. **OLD Energy values for VAh, Wh, VARh, -VARh is available.**

3.1.1.1. Accuracy

Table 2.5: Accuracy Table
Class 1.0 (standard) and Class 0.5 (ordering option)

Measurement	Accuracy	
	Class 1.0	Class 0.5
Voltage LN, per phase	1.0	0.5
Voltage LL, per phase	1.0	0.5
Voltage LN, avg	1.0	0.5
Voltage LL, avg	1.0	0.5
Amp, per phase	1.0	0.5
Amp, avg	1.0	0.5
Amp, phase angle per phase	2°	1°
Frequency	0.1	0.1
Real power, (kW) per phase & total	1.0	0.5
Reactive power, (kVAR) per phase & total	2.0	1.0
Apparent power, (kVA) per phase & total	1.0	0.5
Active energy, (kWh) import/export	1.0	0.5
Reactive energy, (kVARh) (Ind / Cap)	2.0	1.0
Apparent energy, (kVAh)	1.0	0.5

- Note 1: Additional error of 0.05 % of full scale for meter input current below 100 mA.
- Note 2: PF error limit is same as W error limit in %.

3.1.2. Auxiliary Power Supply

The meter needs a single-phase ac or dc **control supply** to power its internal electronics.
Auxiliary power supply range: 44 to 300V ac dc.
Burden (load) < 3 VA (auxiliary supply)

3.1.3. Front Panel Display

- Brilliant 3 lines 4 digit (digit height 14.2 mm) per line, **patented high readability alpha numeric LED display** with auto scaling capability for Kilo, Mega, Giga.
- The display provides the user access to all phase Voltages (phase to neutral and phase to phase), Currents (per phase and total), Watts, VARs, VA, Power Factor, Frequency and kWh, kVAh and kVARh.
- The EM 6400 displays total volts, amps and frequency simultaneously.
- **Load bar graph for the indication of the consumption in terms of %A avg.**
- Easy setup through keys located on the faceplate for common configuration parameters.
- Password protection on setup parameters.

3.1.4. Installation & Input Ratings

- Auto-ranging voltage inputs should allow direct connection up to 347 VLN /600 VLL ac systems (no PTs required up to 600 VLL phase to phase).
- Supports (field configurable) direct 4-Wire Star (Wye), 3-Wire Star (Wye), 3- Wire Delta configurations and single phase via Star (Wye) Phase 1.
- 3-phase voltage and current inputs
 - Volts: 48 to 347 Vac Phase–Neutral, 80 to 600 Vac Phase-Phase,
Overload – Continuous 600 VLL with full accuracy, 750 VLL Max, Hz. 50 / 60
 - Amps: 20 mA to 6 A, Overload: 10 A continuous, 50 A for 3 seconds
 - Field configurable for 5 A or 1 A secondary CTs
 - Burden (Load): Less than 0.2 VA per Volt / Ampere input
 - Frequency: 50 / 60 Hz 45 to 65 Hz

3.1.5.Environmental Conditions

- Sealed dust-proof construction. Meets IP51 for the front panel
- Temperature operating: – 10 to 60 °C, (14 to 140 °F)
Storage: – 25 to 70 °C, (-13 to 158 °F)
- Humidity : Below 5% to 95%, non-condensing

3.1.6.Safety Construction

- Self-extinguishable V0 plastic, double insulation at accessible areas.
- Pollution Degree II
- Measurements Category III

3.1.7.Dimensions & Shipping

- Basic unit installed depth 80 mm behind bezel with **92x92** mm panel cutout, flush mount.
The Protection cover affixed over the rear terminal block extends the depth to 82 mm.
 - Bezel dimension 96 x 96 mm. Panel Cutout **92 x 92** mm
 - Weight 400 gms approx Unpacked, 500 gms approx shipping
- See Chapter 5: Mechanical Installation.

3.2. Display parameters with the EM 6400 DigitAN meters

The EM 6400 can measure, locally display and remotely transfer over MODBUS RTU, the following parameters

Parameter	EM 6459	EM 6433	EM 6434	EM 6436	EM 6400
RMS					
V LL VLN	•			•	•
V12 V21 V31 V1 V2 V3	•			•	•
A	•	•		•	•
A1 A2 A3	•			•	•
F	•			•	•
%L - Amps	•			•	•
%Unbal - Amps	•			•	•
PF	•			•	•
PF1 PF2 PF3	•		•	•	•
%A FS	•	•	•	•	•
Analog colour coded load bar	•			•	•
RPM	•				•
A ⁰ Phase Angle	•				•
A ⁰ 1 A ⁰ 2 A ⁰ 3					•
W		•	•	•	•
W1 W2 W3					•
VA			•		•
VA1 VA2 VA3					•
VAR			•		•
VAR1 VAR2 VAR3					•
THD					
V%1 V%2 V%3					<input type="checkbox"/>
A%1 A%2 A%3					
Demand W or VA					
Rising demand					
DM					
Time remaining					<input type="checkbox"/>
MD Maximum demand					
Hr MD occurred					
INTG					
Wh		•	•	•	•
VAh			•		•
VARh			•		•
-VARh			•		•
Run hours		•		•	•
ON hours					•
Interruptions					•
INTG WITH I/E					
Wh					<input type="checkbox"/>
VAh					
VARh					
-VARh					
Run hours					
OLD					
Wh		•	•	•	•
VAh			•		•
VARh			•		•
-VARh			•		•
Run hours		•		•	•

NOTE

- = Standard Features
- = Ordering Option

Note: This document is applicable for:
All models - v03.02.12.
EM6400, EM6459, EM 6434 – v03.02.02.
EM 6436, EM 6433 – v03.02.11.

The EM 6400 displays:

- **Voltage:**
Three voltage measurements line-to-line: 1-2, 2-3, 3-1 and average,
Three voltage measurements line-to-neutral: 1-4, 2-4,3-4 and average.
- **Current:** Three current measurements phase-wise: 1, 2, 3, one average current of all three phases and three current phase angles A_1^o , A_2^o , A_3^o w.r.t. the corresponding voltage line-neutral vector.
- **Phase wise load in %:** Three currents in % of the FS (%A FS).
- **Unbalanced load in %**
- **Frequency:** Measured from whichever phase is active.
- **RPM:** Measures the speed of the generator.
- **Power:** VA, W, VAR. per phase and total. PF per phase and 3phase. Per-Phase W readings provide a quick CT Polarity Check. A negated W phase reading indicates CT reversal.
- **Energy:** VAh, Wh, +VARh (Ind), -VARh (Cap), Run Hrs, On Hrs, Supply Interruptions (outage)
- **Energy (OLD):** VAh, Wh, +VARh (Ind), -VARh (Cap)
- **% Average Load Bar graph:** Load bar graph indicates consumption in terms of %Aavg. Now you can quickly estimate the load by viewing the display without operating any keys. The bar graph consists of 12 segments. Each segment indicates a load of 10% of CT primary.
- **Kilo, Mega, Giga [indication](#)** for the above parameters.

3.3.Keypad Operation

Figure 3.1 shows a flowchart of Key Operations

Then, follow these simple steps:

- First take a quick look at [what the Keys do](#). Try the simple [example](#) (table 2.4)
- Now, try getting around to other parameters, by moving up, down, right and left. The readings are organized as display pages to the right of “RMS” and “INTG”.
 - The “Kilo”, “Mega” and “Negative” [Indicators](#) are automatic. “Kilo” and “Mega” light up together to show “Giga”.
- You cannot go left into the PROG menu (“RUN”) unless you enter a enter code
- Once in the PROG menu (“RUN”), you can go down to “CLR” or “SET”. Going right though the “CLR” page allows you to clear the integrator. Similarly, keep going right through “SET” to program the meter settings. When done:
 - Go Left all the way back to the PROG menu
 - Go Up to “RUN”
 - Go Right into RMS to view the display pages again.

Figure 3.1: The Display Flow Chart EM 6400, EM 6434 and EM 6459 v03.02

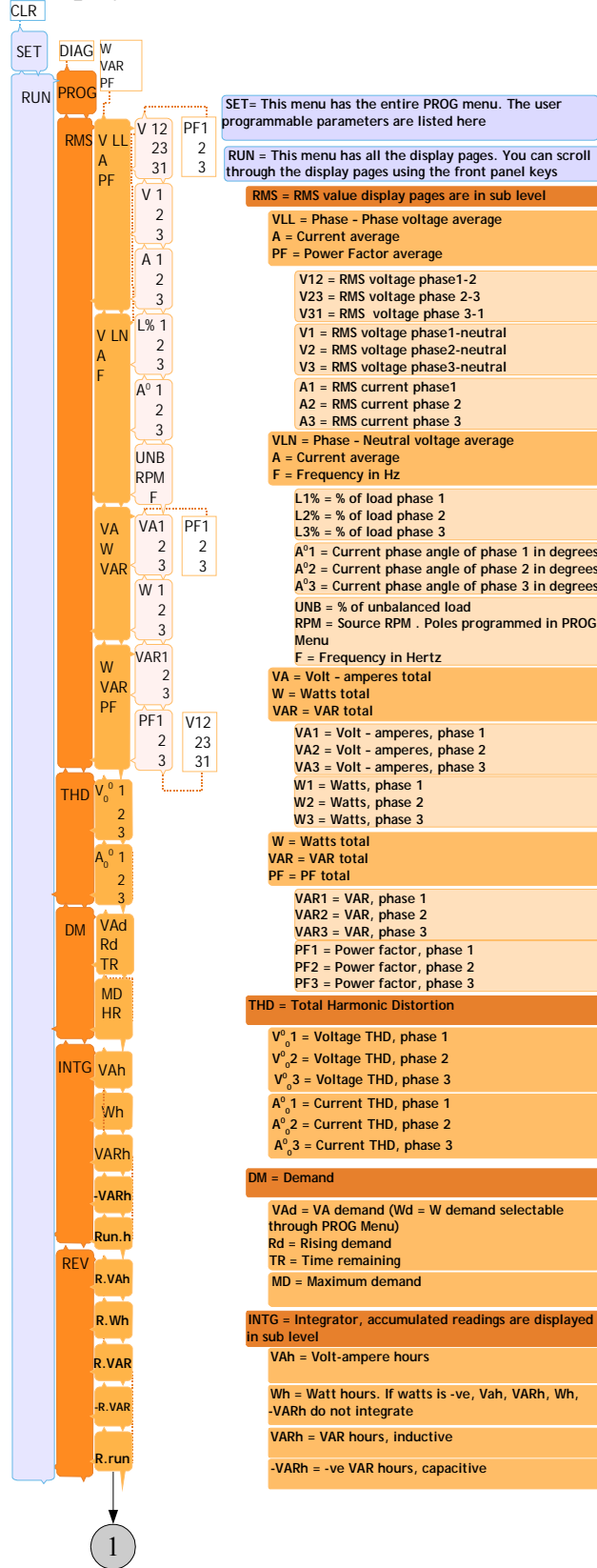

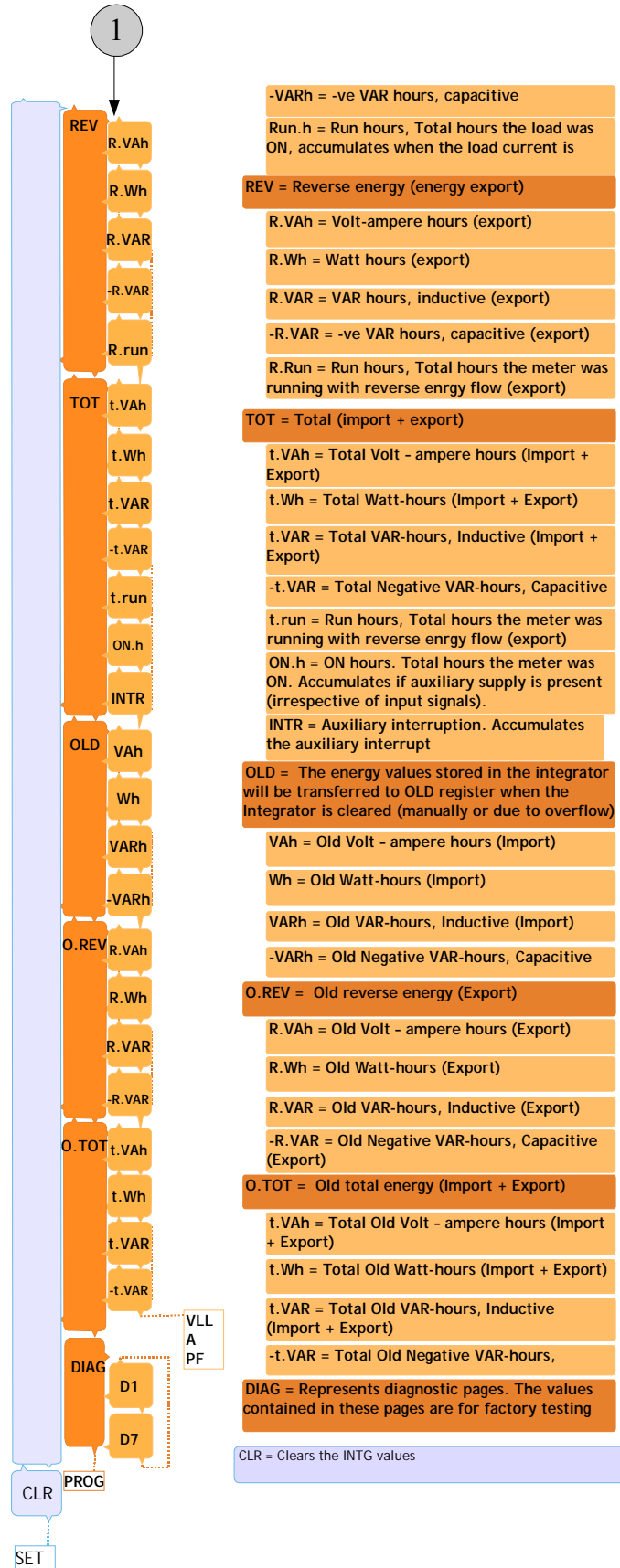

Figure 3.1: The Display Flow Chart EM 6433 v03.02.11 & v03.02.12

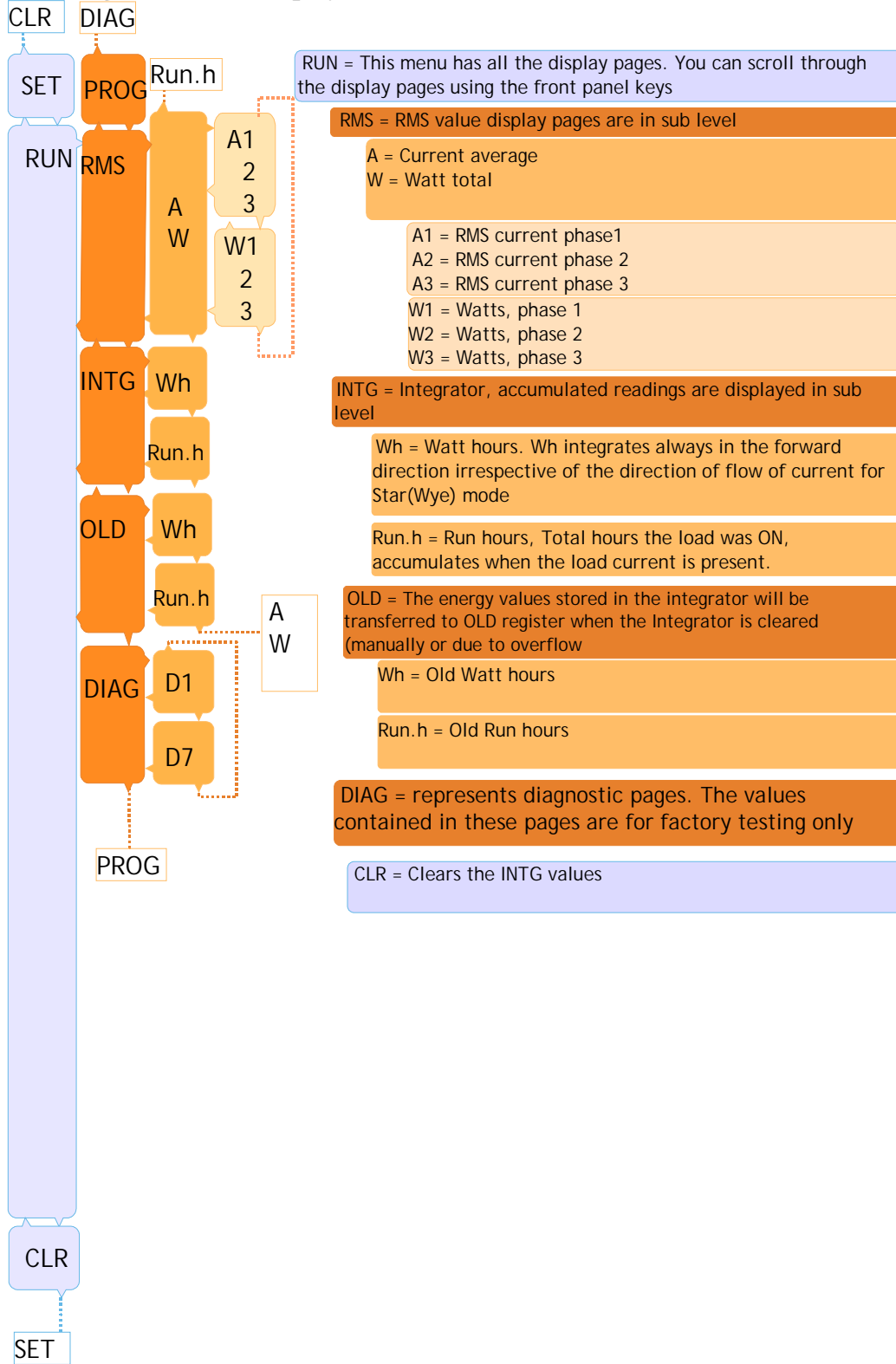
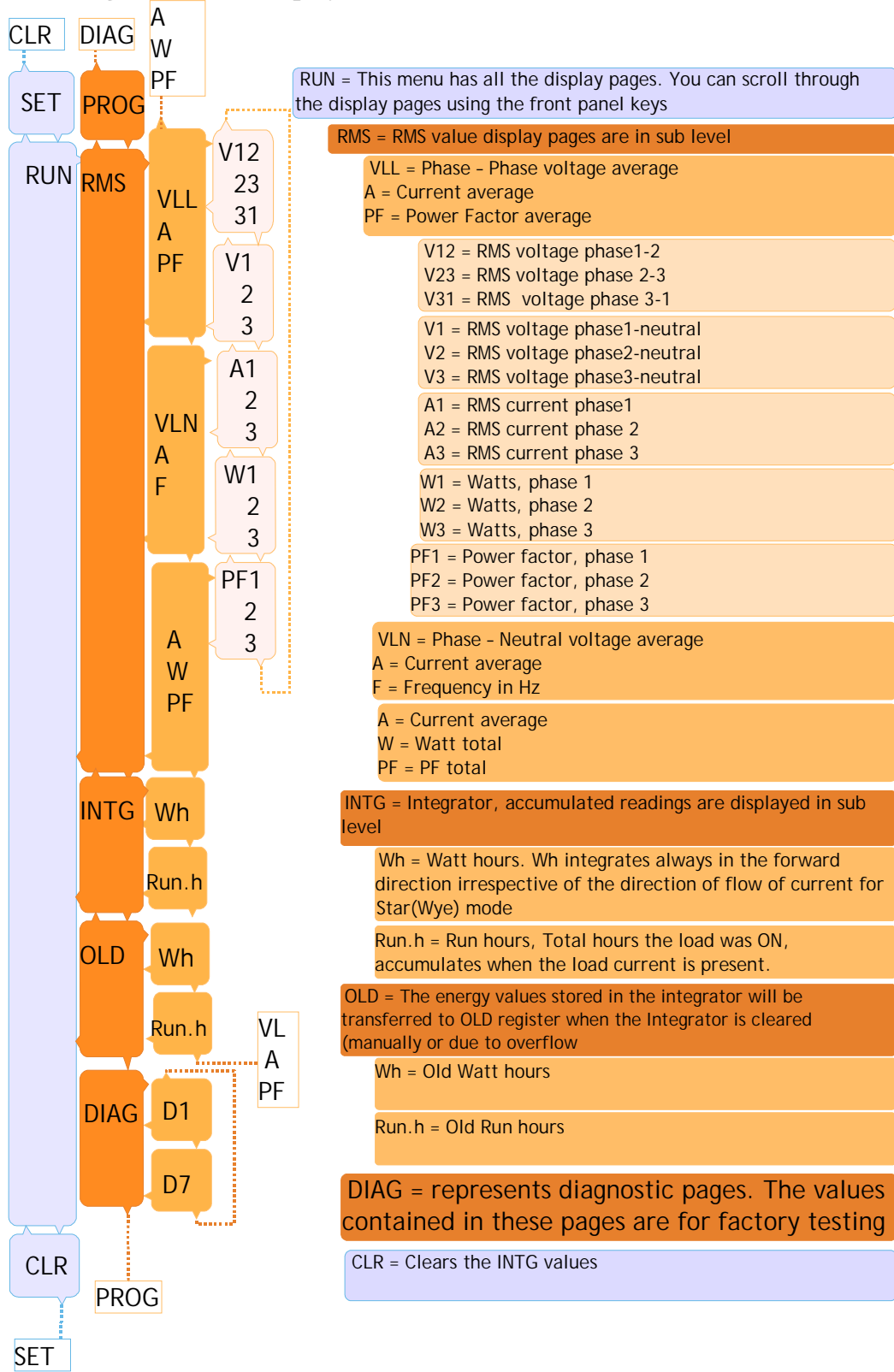





Figure 3.1: The Display Flow Chart EM 6436 v03.02.11 & v03.02.12



3.3.1.Auto-Scroll



Auto-Scroll allows you to monitor a group of Display Pages sequentially, every 5 seconds, without constant key pressing. This is convenient for viewing from a distance. Since the EM 6400 displays the Parameter Name (1 sec) followed by the Value (4 sec) on the same large displays, both are equally readable from a distance. No more squinting at a clutter of parameter indicators.

To enter auto-scroll, go to the desired display page and keep the Up  or Down  key pressed for minimum 3 seconds, then release key. The display flashes “Auto” and then automatically scrolls through other pages at the same level (column in the above table). Press any key to revert to Manual Scrolling.

- The Up  key enters Page Auto-scroll – within the TURBO Pages,
- The Down  key enters Full Auto-scroll- down the entire column of pages.

3.3.2.Default Display (View) Page – Only in v03.02.11 & v03.02.12 EM6436 & EM6433

You can select any page as “User-Set” display page. You can scroll to other display pages. The “User-Set” page is displayed 2 minutes after manual scrolling was stopped by the user. How to lock?

- Go to the page you want to set as default page
- Press  and  keys together

How to unlock?

- Once Default Display Page is active, press  and  simultaneously to unlock the Key page meter displays”ULOC”.

Note: Entry in to set up (PROG) is allowed when the” Display Page” is unlocked.

3.3.3.TURBO key

The TURBO key scrolls through the following pages:

'VLL, A, PF' 'VLN, A, F' 'VA, W, VAR' ' W, VAR, PF' 'PF1, PF2, PF3' '**V%1,**

V%2,V%3' **A%1, A%2, A%3** 'VA.d, R.d, t.r' '**md, hr**' 'VAh' 'Wh' '**R.VAh**

'**R.Wh**' '**t.VAh**' '**t.Wh**'. This gives simple one-touch access to the most commonly used parameters, even for unskilled operators. “One-touch” does not operate in the PROG menu - Setup. Optional parameters are with bold characters.

Note **EM6436**, TURBO key scrolls through the following pages:

RMS (home page), VLL, A, PF VLN, A, F A, W, PF PF1, PF2, PF3 Wh and Run hours.

EM 6433, TURBO key scrolls through the following pages:

RMS (home page), A, W Wh and run hours

- **If you're lost, the TURBO key is a quick way to get back to the RMS home page.**
- Continuous pressing for 3 seconds initiates Auto-scrolling through the above TURBO pages.

3.4.PROG menu – Setup

The meter must be set (programmed/configured) to match the application settings, before use. Otherwise, the readings will be wrong. All the Setup values can be re-programmed at any time, upon entering “SET” However, the settings: SYS (Star/gye or Delta), Vpri, Vsec, Apri, Asec critically determine the scaling of measured readings. While the scaling may be used to tune out Instrument Transformer errors, wrong settings will upset the readings of running systems.

CAUTION: The meter does NOT lock out these settings – it allows professional tuning of these settings on a running meter. It is the user’s responsibility to ensure that only qualified personnel correctly Setup the Meter.

You can enter the PROG menu in

Edit mode – to view or edit set parameters – Section 3.4.1

View only mode - to view the set parameters – Section 3.4.2

3.4.1.Enter PROG Menu in Edit Mode

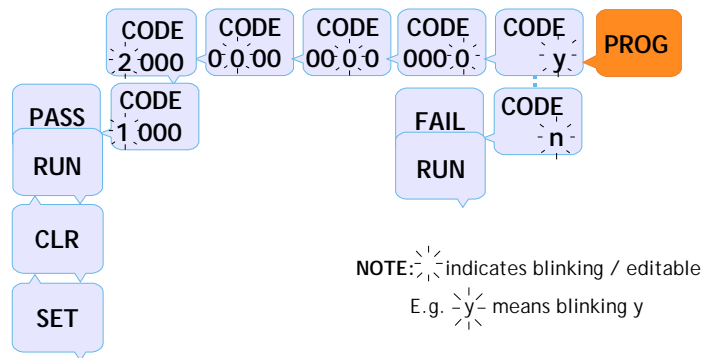

- Step1: From PROG, go left . The display will show “CODE Y” with the “Y” blinking
- Step2: To continue with the code entry scroll left using the left key
- Step3: Press 3 times. The blinking zero will shift position one place leftwards with each key press
- Step 4: Now 2 starts blinking
Press to change the blinking from 2 to 1
You have now entered the factory set code to 1000
- Step5: Press to confirm the code
The display shows “PASS” and then “RUN”
“PASS” indicates that you have successfully entered the code and entered PROG Menu – Setup

If the display shows “FAIL” – means that you have not successfully entered PROG Menu, don’t despair. Try again from step1
Restart the meter to easily return to the RMS page to re-enter the code.

3.4.2. Enter PROG Menu in View (read – only) mode

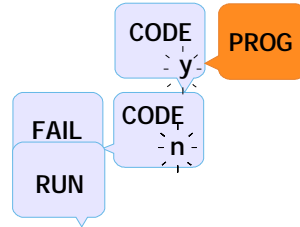

Step1: Go . The display will show “CODE Y” with the “Y” blinking

Step2: Go . The display will show “CODE N” with the “N” blinking

Step3: Go . to continue with PROG menu entry in view mode

Step4: The display shows “FAIL” and then “RUN”

You have successfully entered the PROG Menu – Setup in the view mode

Step5: Press again, display shows SET

You are at the PROG Menu now. Press to enter the menu and view the set parameters

Note: You cannot go left into the PROG menu (“RUN”) unless you enter a code

- Once in the PROG menu (“RUN”), you can go down to “CLR” or “SET”.
- Going right through the “CLR” page allows you to clear the integrator.

Similarly, keep going right through “SET” to program the meter settings

When done:

- Go Left all the way back to the PROG Menu
- Go Up to “RUN”
- Go Right into RMS to view the display pages again

Complete PROG Menu listing all the parameters is shown in section 4.

3.4.3. Enter PROG Menu on Power ON

An easy way to enter PROG Menu

- During power ON, press the key for 2 sec continuously
- Meter displays SET
- Press key displays the desired value to be changed.

Edit the setup parameters as explained in section 4.

4. Entire List of PROG Menu – Setup Parameters

SET	SYS	STAR	SET= This menu has the entire PROG menu. The user programmable parameters are listed here
	V.PRI	415.0	
	V.SEC	415.0	SYS= Power system's configuration*: STAR , DELTA
	V.PRI	415.0	V.PRI= Voltage primary winding (PT), line-line* Input range: 100 v to 999 kv (415.0)
	V.SEC	415.0	V.SEC= Voltage secondary winding (PT), line-line* Input range: 50 v to 530 v (415.0)
	A.PRI	0100	A.PRI= Current primary winding (CT)* Input range: 1 A to 99 kA (100.0)
	V.SEC	415.0	A.SEC= Current secondary winding (CT)* Input range: 1 A to 7.5 A (5.000)
	A.PRI	100.0	LABL= Phase labeling Choose from: 123 , RYB, RST, PQR, ABC
	A.SEC	5.000	VA.FN= VA function selection* Set the VA function to: 3D , ARTH
	LABL	123	d.SEL= Demand selection*: auto , user
	A.SEC	5.000	d.PAR= Demand parameter*: VA , W
	LABL	123	d.PRd= Demand period: 5,10, 15 ,20,25,30
	VA.Fn	3D	Baud= Baud rate : 1200, 2400, 4800, 9600 , 19200.
	d.SEL	AUTO	PrtY = Parity & Stop bit settings: EVn.1 , EVn.2, Odd.1, Odd.2, no.1, no.2
	VA.Fn	3D	Id = RS485 Device ID number: 001 to 247. (Evn.1 = Even. 1 stop bit)
	d.SEL	AUTO	F.S%= Full scale % Set the full scale between 1 to 100: 100
	d.PAR	VA	O.F = overflow parameter selection : Wh , VAh - INTG clears when 99999999
	d.PRD	15	POLE= Number of poles for RPM Choose from: 2, 4 ,6,8,10,12,14,16
	BAUD	9600	
	d.PRD	15	
	BAUD	9600	
	PRTY	EVN.1	
	BAUD	9600	
	PRTY	EVN.1	
	ID	1.000	
	PRTY	EVN.1	
	ID	1.000	
	F.S	100.0	
	O.F	Wh	
	F.S	100.0	
	O.F	Wh	
	POLE	4.000	
	O.F	Wh	
	POLE	4.000	
	POLE	4.000	

Default Setup values are give in **BOLD**

*Changing these values while the device is in use, is not recommended.

Note: The PROG menu of EM 6433 and EM 6436 will not have "POLE" option
d.SEL, d.PAR, d.PRd are present only in meter with DM(Demand) option

4.1. Edit Set Parameters in PROG Menu

This example explains how to edit the system type from “STAR” to DELTA” in the PROG Menu of EM 6400 meter.

For easy understanding we have explained edit PROG Menu in 2 parts.

4.1.1. Edit and accept setup

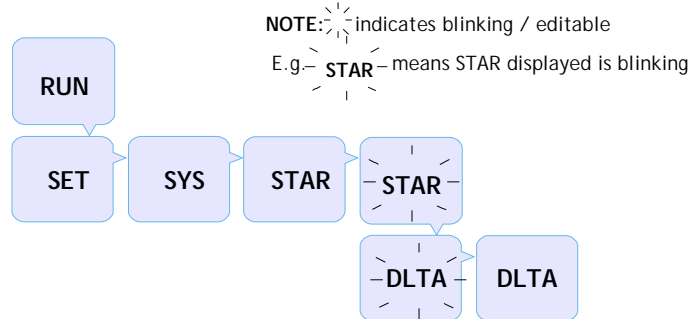



Step1: From “RUN”, go  until “SET” is displayed. Refer Section 3.4.1 to enter PROG menu

Step2: Go  the display shows ”SYS”

Step3: Go  the display shows “STAR”

Step4: Press , the display shows “STAR” blinking. This means that the parameter value can be edited now.

Step5: Press  the display shows “DLTA” blinking. This means that the value for SYS has been changed to delta.

Step5: To accept the new value, press 

“DLTA” stops blinking. This means that the new value for SYS has been accepted.

4.1.2. To save the new value to setup

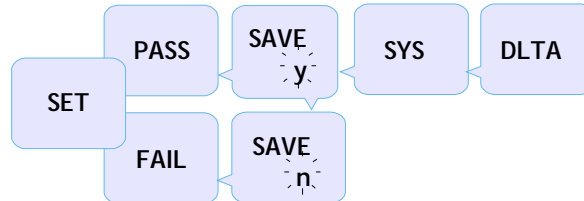



NOTE:  indicates blinking / editable

E.g.  means blinking y

Step6: After completing upto step6 above, go  The display shows “SYS”

Step7: Go  The display shows “SAVE Y” with “Y” blinking

Step9: If you want to save the edited settings go . The display will flash “PASS” for sometime and then “SET”

Note: If you do not want to save the edited settings, after step9 go  The display shows “SAVE N” with “N” blinking

Now go  the display flashes “FAIL” for sometime and then “SET”

4.1.3. Clear INTG and MD

EM 6400 series products are equipped with Energy Integrator INTG, where the energy parameters are accumulated.

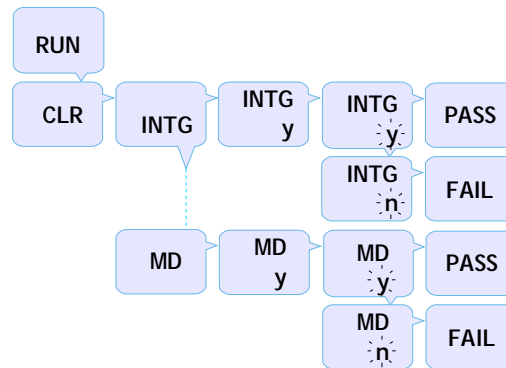

Note: INTG Clear – clears both INTG and MD

MD Clear – clears only MD

INTG Clear

Step1: Enter the PROG Menu

Step2: When the display shows “RUN”, go . The display shows CLR.

Step3: Go . You have entered the CLR menu and the display shows “INTG”

Step4: Go to proceed with INTG clear. The display shows “INTG Y” with blinking “Y”

This is to prompt you that you are about to Clear the data stored in INTG.

If you do not want to clear INTG, go . The display shows “INTG N”. Go

The display shows “FAIL” which indicates failure in clearing INTG. Now go to step 6.

Step5: Go once to clear INTG. “PASS” flashes on the display followed by INTG.

INTG is cleared and the data is transferred to the OLD register.

If is pressed more than once, the integrator value will not be transferred to OLD register and will be lost

Step6: Press to exit.

Now you are back in the PROG Menu and go to “RUN”

Now go to “RMS”

MD Clear

MD is an ordering option to be specified at the time of purchase

Step1: Enter the PROG Menu.

Step2: When the display shows “RUN”, go . The display shows “CLR”.

Step3: Go . You have entered the CLR menu and the display shows “INTG”

Step4: Go to proceed with MD clear. The display shows “MD”

Go the display shows “MD y” with “Y” blinking, this is to prompt you that you are about to clear the stored data in INTG.

If you do not want to clear MD, go . The display shows “MD N”

Go

The display shows “FAIL” which indicates failure in clearing MD. Now go to step6.

Step5: Go once to clear MD. “PASS” flashes on the display followed by MD.

MD is cleared and the data is transferred to OLD register.

If is pressed more than once, the integrator value will not be transferred to OLD register and will be lost

Step6: Press to exit

Now, you’re back in the PROG Menu and can go to “RUN”

Now go to “RMS”

4.1.4. Energy Integrator

Your EM 6400 meter is equipped with an Energy Integrator function which provides several parameters for Energy Management: VAh, Wh, VARh (Ind), -VARh (Cap), run.h (run hours), on.h (on hours), INTR (Interruptions / outages).

A few of these need explanation:

run.h: Indicates the period the Load is ON and has run. This counter accumulates as long as any one Amps phase has more than 10mA through the meter terminal.

on.h: The period for which the meter (supply) is ON

INTR: Number of Supply Outages, means the number of Auxiliary Supply interruptions. If the meter Auxiliary Supply is from a UPS then the INTR (number of interruptions) will be zero (as long as the UPS stays ON), even if the Voltage Signals did die out from time to time

Note: CT Reversal: auto - correction for Energy Integration in Star (Wye) mode (applicable for models - EM 6433 & EM 6436, v03.02.11 & v03.02.12). In Star (Wye) mode energy integration always be in forward direction irrespective of the direction of current flow or sign of the per phase power reading.

4.1.4.1. Integrator Overflow

Your EM 6400 meter contains a comprehensive “Integrator” to support Energy Management. It accumulates several parameters over time, as explained above. All values are Direct Reading and have a high resolution. This is necessary for accurate energy analysis over short intervals of time. It also means that the readings max out and reset sooner or later as given below. Since the Integrator contains counters for several parameters (VAh, Wh, VARh, -VARh, Run Hours, On Hours, Interruptions), they all reset together whenever any one of them overflows (usually Wh – but can be changed to VAh via the OF Setup). This makes energy management calculations such as Average PF very easy.

The maximum number that the Meter handles is 9,999 Giga for RMS and Energy values. The value at which the meter overflows is given below. See Table 3.4 “Integrator [Overflow Value](#)”.

The Overflow value depends on the Product of the PT Ratio and CT Ratio that you’ve programmed for your application.

$$\text{PT Ratio} * \text{CT Ratio} = \frac{V_{pri}}{V_{sec}} \times \frac{A_{pri}}{A_{sec}}$$

Table 3.4: Integrator Overflow Value

PT ratio x CT Ratio	Max Reading Wh/VAh	Time taken for Overflow (months)	
		Min	Max
1 to 1.999	9999K	1.92	3.85
2 to 1000.999	9999M	3.85	1928.81
Greater than 1001	9999G	3.85	3857.63

4.2. Summary

We have now learnt

1. To operate the EM 6400 Series products.
2. To configure its Setup and
3. To clear its Demand and Integrator readings.

5.AC POWER MEASUREMENT

This Chapter describes the following:

1. Fundamentals of Three-Phase Measurements

5.1. Three-Phase Systems

A three-phase system delivers higher levels of power for industrial and commercial applications. The three phases correspond to three potential lines. A 120° phase shift exists between the three potential lines.

A typical configuration has either a Delta connection or a Wye (Star) connection (see **Figure 4.1**, below).

In a three-phase system, the voltage levels between the phases and the neutral are ideally defined by $V_1 = V_2 = V_3 = V_{12} / \sqrt{3} = V_{23} / \sqrt{3} = V_{31} / \sqrt{3}$. In practice, there will be some unbalance (difference).

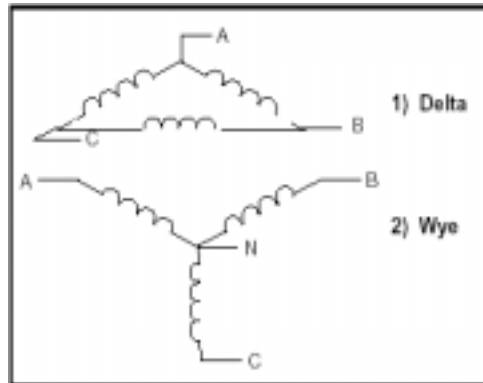

Figure 4.1: Three-Phase System: (1) Delta, (2) Star (Wye)

Voltages between the phases vary depending on loading factors and the quality of distribution transformers.

Power measurement in a poly phase system is governed by **Blondel's Theorem**. Blondel's Theorem states that in a power distribution network, which has N conductors, the number of measurement elements required to determine power is N-1. A typical configuration of poly phase system has either a Delta connection or a Star (Wye) connection (see **Figure 4.2** below).

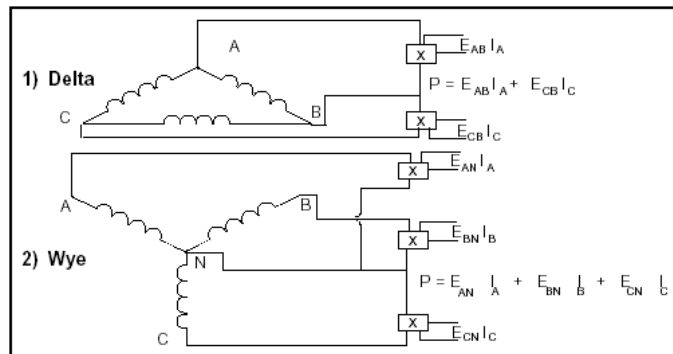

Figure 4.2: Poly Phase System: (1) Delta, (2) Star (Wye)

5.2. Consumption & Poor PF

CONSUMPTION: $Wh = W \times T$, where W = instantaneous power T = time in hours
 The total electric energy usage over a time period is the consumption of Wh .
 Typically, the unit in which consumption is specified is the kilowatt-hour (kWh): one thousand watts consumed over one hour. Utilities use the Wh equation to determine the overall consumption in a billing period.

POOR POWER FACTOR: Results in reactive power consumption. Transferring reactive power over a distribution network causes energy loss. To force consumers to correct their Power Factor, utilities monitor reactive power consumption and penalize the user for Poor Power Factor.

5.3. “3D” kVA Measurement

The EM 6400 is equipped with 3D Measurement of kVA. This advanced method provides the most accurate and predictable measurement under unbalanced as well as distorted waveform conditions.

However, in case the EM 6400 needs to match the reading of older or simpler meters, which use the Arithmetic kVA definition, this too is available as a Setup option.

Table 4.1: VA Function Setup Options

kVA Function	Formula	Other Names	Which one?
3D Factory setting	$kVA_{3D} = \sqrt{\sum W^2 + \sum VAR^2 + \sum D^2}$ where D = Distortion Power per IEEE 100	U, Apparent, Vector kVA	Best, all around
Arth	$kVA_{Arth} = kVA_1 + kVA_2 + kVA_3$	Arithmetic, Scalar kVA	Good under Low unbalance, to match simpler meters without 3D capability

6.MECHANICAL INSTALLATION

The EM 6400 is panel-mounted and has reliable, rear-mounted terminal strips rated at 600v. The 92 x 92 mm cut-out and 96 x 96 mm bezel dimensions adhere to DIN IEC 61554 and DIN 43700.

Depth required behind the Bezel is 80 mm, plus space for wiring. Two side clamps are

CAUTION ⚠ :

All Installation, wiring and maintenance instructions to be carried out by qualified personnel only.

Please read this and the following chapter completely, before proceeding

provided for firm mounting.

Diagram below displays the various dimensions of mechanical installations.

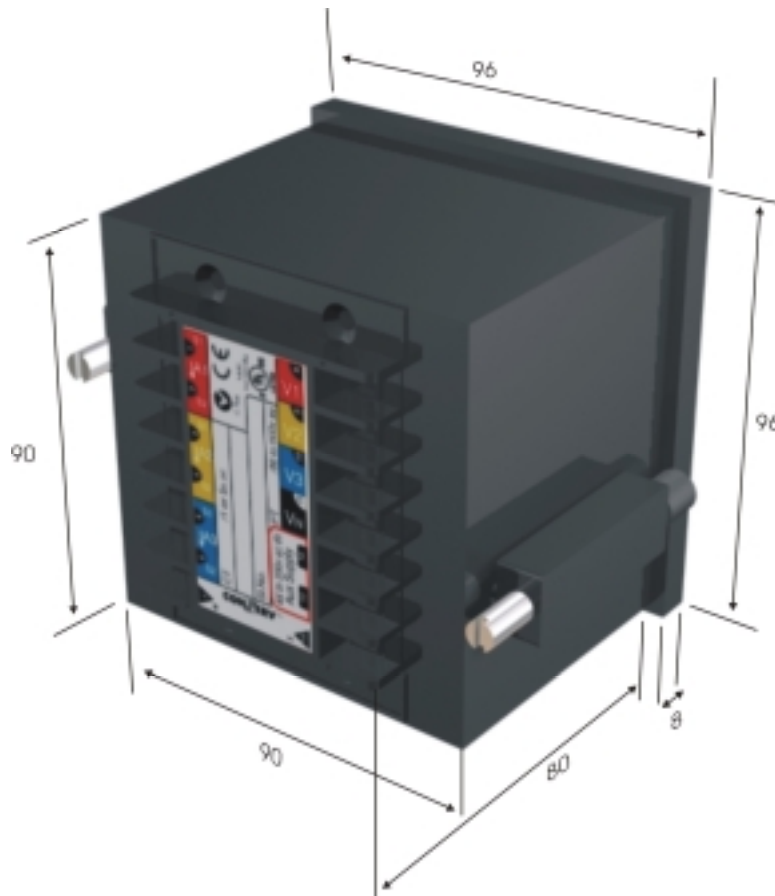

RECOMMENDED CUTOUT

92 x 92 mm

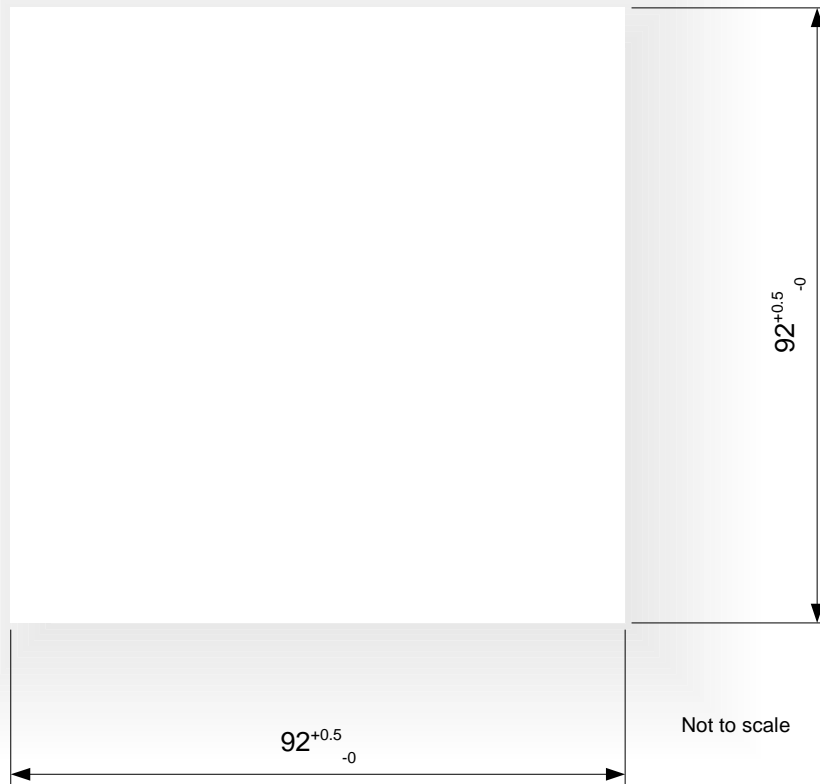

6.1. Installation Procedure

6.1.1. Panel Mounting for New Installations

6.1.1.1. Location and Mounting considerations

DANGER ⚡:

All Installation, wiring and periodic maintenance of the EM 6400 as well as its associated circuits involves high voltages and currents. While this manual suggests several safety and reliability steps, it must be used in conjunction with the safety codes in force at your location. Failure to practice safe working procedures is likely to cause damage to the installation, severe injury and / or death. All work including handling of electrical circuits during Installation, wiring and periodic maintenance, must be done only by qualified personnel.

Neither CONZERV nor its agents may be held responsible for damage or death arising out of the wiring and / or PT, CT or other external circuits.

The covers of the EM 6400 should never be dismantled or opened. There are no user-serviceable parts inside. The EM 6400 contains high-precision components which require special handling available only at authorized CONZERV service locations. High voltages are likely to be present inside even after the EM 6400 has been switched off. Opening the covers of the EM 6400 and/or any attempts to dismantle, service, repair or modify the unit by unauthorized persons may cause severe injury, will damage the unit and will also render CONZERV's warranty void.

6.1.1.2. Usage

First, decide on how the EM 6400 is going to be used. If you do not already have an energy management program in operation, then your energy consultant should be able to help you identify which load(s) offer maximum savings potential. This will help you decide which point is to be monitored, where the readings will be viewed from, who must have access to the instrument and how often. For best performance, choose a location, which provides all the required signals with minimum wiring lengths.

6.1.1.3. Panel Considerations and Environment

The EM 6400 is a high - precision measuring instrument and its operating environment is of utmost importance. For maximum performance, the instrument should be mounted in a dry, dust-free location, away from the heat sources and strong electromagnetic fields. To operate reliably, the following conditions must be met:

Storage Temperature	-25 ^o to 70 ^o C, (-13 ^o to 158 ^o F)
Operating Temperature	-10 ^o to 60 ^o C, (14 ^o to 140 ^o F)
Relative Humidity	5% to 95%, non-condensing

The EM 6400 should be separated from other equipment and sufficient space must be provided all around for cooling air to rise vertically past the instrument. The cooling air temperature must be below the specified operating temperature.

The panel or housing, in which the EM 6400 is mounted, should protect it from dust, moisture, oil, corrosive vapours, etc.

The panel doors must be easily opened to provide easy access to the EM 6400 wiring for trouble-shooting. Allow clearance if the unit is going to swing out, as well as adequate slack in the wiring. Allow space for terminal blocks, CT shorting blocks, fuses, auxiliary contractors and other necessary components.

6.1.1.4. Viewing

For ease of operation, in the location should be preferably at, or slightly above, eye-level. For viewing comfort, minimize glare and reflections from strong light sources.

6.1.1.5. Mounting

Before mounting and wiring, the [Setup procedure](#) (see section 3.2) should have been completed.

The EM 6400 is panel mountable.

Panel cut-out	92 ^{+0.5} -0 (w) x 92 ^{+0.5} -0 mm (h) DIN IEC 61554 and DIN 43700
Panel Thickness	0.5 to 4.0 mm
Instrumental Bezel dimension	96 x 96mm
Depth behind Bezel	80 mm. (82 mm with terminal cover. Leave clearance for wires.)
Mounting Clamp Screws	Slotted, 2 nos
Terminal Screws	Combination Phillips & Slotted head

The cutout should be punched with the proper tool and should be free from burrs. Before wiring, insert the EM 6400 into the cutout from the front. Then, fasten the two side clamps from the rear. While supporting the EM 6400 from the front, tighten both side clamp screws in a criss-cross pattern till all slack is taken up and then apply one full turn. Do not over-tighten.

7.ELECTRICAL INSTALLATION

DANGER 

All Installation, wiring and periodic maintenance of the EM 6400 as well as its associated circuits involves high voltages and currents. While this manual suggests several safety and reliability steps, it must be used in conjunction with the safety codes in force at your location. Failure to practice safe working procedures is likely to cause damage to the installation, severe injury and / or death. All work including handling of electrical circuits during Installation, wiring and periodic maintenance, must be done only by qualified personnel.

Neither CONZERV nor its agents may be held responsible for damage or death arising out of the wiring and / or PT, CT or other external circuits.

The covers of the EM 6400 should never be dismantled or opened. There are no user-serviceable parts inside. The EM 6400 contains high-precision components which require special handling available only at authorized CONZERV service locations. High voltages are likely to be present inside even after the EM 6400 has been switched off. Opening the covers of the EM 6400 and/or any attempts to dismantle, service, repair or modify the unit by unauthorized persons may cause severe injury, will damage the unit and will also render CONZERV's warranty void.

This Chapter describes the following:

- The Need and selection of potential transformers (PTs) and current transformers (CTs)
- Auxiliary Supply, PT and CT Connections

NOTE: For best wiring results with the terminals, please ensure the following specs:

Improper wire-man-ship will damage the terminals and require factory replacement. This does not indicate defective manufacture and is not covered by product warranties.

- Power driver preferred, hand screwdriver OK.
- TIP: Phillips preferred, DO NOT USE POZIDRIV TIPS. Flat OK



Screw Head Diameter = 3.5mm, TIP Shaft Diameter < 5mm.

IMPORTANT - Driver Shafts inserted angularly or of diameter = 5mm or more **WILL GET STUCK** in the Safety Cover

Tightening Torque: 25 to 60 N-cm

Loosening Torque: 55 to 60 N-cm

Screw Travel: 6 mm less wire thickness

Torque greater than 60 N-cm may strip the screw or break the safety cover.

Worn-out bits and insufficient hold-down pressure while tightening will cause the bit to ride on the screw head thus stripping and damaging it.

7.1. Auxiliary (Control) Power Supply

DANGER ⚡: Do not feed the EM 6400's auxiliary power supply terminals with a voltage greater than the rating marked on the label. The EM 6400 will be permanently damaged and CONZERV's Warranty shall be void.

The EM 6400 DigitAN series meter requires a single-phase ac / dc Auxiliary (control) power supply to power up its internal electronic circuitry. The [Setup](#) procedure (Section 3.2) must first be completed, with only the auxiliary supply connected.

External surge suppressors are necessary in the auxiliary supply circuit for proper operation during extreme surge conditions, where the voltage surges exceed the auxiliary supply limits (E.g. Rural areas and outlying areas prone to lightning strikes).

Auxiliary Supply Range:

- 44 to 300V ac / dc.
- Burden (load) < 3VA.

NOTE 1: The auxiliary power supply may be derived from the voltage signals.

NOTE 2: If you have a 440 v three-wire delta system and a reliable neutral is not available, a 440v: 240v Supply transformer should be used to provide the standard 240v auxiliary supply.

7.2. PTs and CTs

Large electrical installations have high voltages and currents, which may exceed the direct connection rating of the meter. In this case, Potential Transformers (PTs) and Current Transformers (CTs) are used to precisely “step down” or reduce the voltage and current level to suit the meter rating. Potential Transformers usually have a full-scale output of 110V ac RMS line-line and Current Transformers, a full-scale output of 5A or sometimes 1A.

The PTs (Potential Transformers) and CTs (Current Transformers) must be planned, installed and tested by a qualified electrical contractor before wiring the meter. The accuracy of the measurement also depends on the accuracy and phase – angle error of the PTs and CTs. Instrument Class 1 or better PTs and CTs are recommended. Do not use protection class (10P10, etc.) CTs to feed the EM 6400; they have poor accuracy and phase characteristics.

Ensure that the CT primary rating has been selected so that your normal load variation lies between 40% and 80% of its full scale. If your CT is over-rated, say if the load is always less than 10% of the CT primary rating, accuracy suffers. On the other hand, if the CT is under-rated, then you may exceed its full-scale and burn out both the CT and the EM 6400.

7.2.1. PT, CT Wiring

The PTs and CTs must have adequate VA rating to support the burden (loading) on the secondaries. You may want to support the auxiliary supply burden from one of the PTs. CT wiring can impose additional burden (loading) on the CT. For example, if the CT has a 5A secondary and the wire resistance is 1.0 Ω , then the CT has to support an additional burden of 5VA. If the wiring distance from the CT secondary is greater than stated in Table 6.1, then the CT could get over-burdened and give large errors. Choosing a 1A CT secondary can reduce this error. The CT Secondary value must be user programmed into the meter.

The EM 6400 should be conveniently located for easy connections of voltage (PT) and Current (CT) signals, the auxiliary (control) supply.

NOTE : The EM 6400's Field Programmable PT and CT Primary or secondary Settings may be utilized to Calibrate out the PT and CT amplitude error, for improved accuracy.

7.3. Voltage Signal Connections

For proper meter operation, the voltage connection must be maintained. The voltage must correspond to the correct terminal. The cable required to terminate the voltage sense circuit should have an insulation rating greater than 600V ac and a current rating greater than 0.1A.

There are 4 input voltage terminals marked V1, V2, V3 and Vn. See the wiring diagrams that follow, for details. **For Delta connection, the Vn terminal should be left un-connected.**

7.3.1. PT Connections

CAUTION ⚡ : Before wiring, de-energize the PT secondary by opening the circuit or removing the fuse. Do not short the PT secondary.

The EM 6000 directly accepts LT voltage inputs of up to 600 V ac RMS Line to Line (347 V L-N). Voltages greater than this, typically HT systems, must be connected through Potential Transformers (PTs). The EM 6400 allows field programming of both PT Primary and Secondary voltages. See the voltage input overload graph for more detail

Field Programmable PT Primary range	: 0.1 to 999 kV ac RMS L-L.
Field Programmable PT Secondary range	: 100 to 600v ac RMS L-L.
EM 6400 Voltage Input burden	: 0.2 VA per input.

See Section 3.2 [Setup \(Field Programming\) section](#) for programming details.

IMPORTANT: The PT primary and secondary values must be user programmed before using the meter. Otherwise, the readings will be wrong.

7.3.2. Selecting the Voltage Fuses

We strongly recommend using fuses on each of the sense voltages and the control / auxiliary power, although connection diagrams often do not show them. Use a 1A fuse on each voltage input.

7.4. Current Signal Connections

The meter accepts up to 6A ac RMS per channel directly. Above that, a Current Transformer must be interposed to scale down the current.

There are three pairs of current input terminals marked A1, A2 and A3. Each pair of input terminal is labelled as (S1, S2) and has an arrow indicating the direction of current flow. For proper measurements, the phase identification as well as the polarity of the current signals must be correct. The forward flow (import by consumer) current direction must be into the S1 terminal and the exit from the S2 terminal. Please maintain the correct sequence and polarity to avoid wrong readings.

Any unused current input terminals (e.g. A2 (S1, S2) for Delta) must be shorted together. The shorted terminals do not need to be grounded.

Install the wiring for the current circuit at 600V ac insulation as a minimum. The cable connection should be rated for 7.5A or greater and have a cross-sectional area of 16AWG minimum.

CAUTION  : Before wiring, de-energize the CT secondary by shorting it via a shorting block.

Under no circumstances must the CT secondary be left open-circuited, even momentarily, when primary current is flowing. This causes high voltages that will overheat and explode the secondary of the CT and damage the instruments as well

7.4.1. CT Connections

Mount the current transformers (CTs) as close as possible to the meter for best accuracy. The following table illustrates the maximum recommended distances for various CT sizes, assuming the connection is via 16AWG cable.

Table 6.1: CT Size and Maximum Distance

5A CT Size	Maximum Distance in meters (in feet) (CT to EM 6400 Meter)
2.5 VA	3.05 (10 feet)
5.0 VA	4.6 (15 feet)
7.5 VA	9.15 (30 feet)
10.0 VA	12.2 (40 feet)
15.0 VA	18.3 (60 feet)
30.0 VA	36.6 (120 feet)

Field Programmable CT Primary range : (1A to 99kA) ac.
 CT Secondary : (1A or 5A) ac (programmable)
 Other values are also programmable to compensate CT errors if desired.
 EM 6000 CT burden : 0.2VA maximum per input.
 See the [Setup \(Field Programming\) section](#) for programming details.

IMPORTANT: The CT Primary and Secondary values must be User Programmed before using the Meter. Otherwise, the readings will be wrong.

NOTE 1: With dual - range CTs, select the best range for programming the EM 6400. Do not change the range thereafter without re-programming the EM 6400; the EM 6400 will read erroneous values.

7.4.2. CT Polarity

When the meter is connected using the CTs, you must maintain the correct CT polarities. CT polarities are dependent upon correct connections of CT leads, and upon the direction the CTs are facing when clamped around conductors. The dot on the CT must face the line side; the corresponding secondary connection must connect to the appropriate input on the meter.

Failure to connect CTs properly results in inaccurate power readings. If your meter is not reading power properly, it is more than likely that the CT is incorrectly wired. If one or two CTs are reversed, then energy parameters accumulate only one phase value. If two or all the phases of the CT are reversed, energy will not accumulate. (energy export will not be measured).

7.4.3.CT Connection Reversal

To check the polarity of the CT after the meter has been installed, simply look at the phase-wise W (Watt) readings to see that each of the readings are positive (assuming you are consuming power). If one of the W readings is negative, that particular phase CT is reversed and must be corrected. On the other hand if you are exporting power, all three phase-wise W readings must be negative.

7.5.Setup – System Type

The EM 6400 needs to know what type of 3-phase system it is connected to. This is programmed in the [Setup procedure](#) (Section 3.2), before using the meter. The meter does allow you to change this setting while it is running; however, this capability is meant for correcting a gross error, or for training or educational purposes, not to be changed regularly. The options are:

- Star (Wye). For three phase four wire, “Three Watt-meter” or “Three Element” circuits. Here, all three voltage Phase signals, the Neutral voltage connection and all three current input signals need to be wired in, means all the 4 voltage terminals and 6 current terminals described in the following section, need to be wired. This setting is also used for single phase circuits. Here, the V1 and VN terminals as well as the A1 (S1 and S2) terminals will be used to sense a single voltage and a single current.
- Delta. For three phase, three wire, “Two Watt-meter” or “Two Element” circuits.

7.6.Phase Labels

The phase labels shown on the display are programmable via the EM 6400 front panel PROG menu. You can setup the meter to display phase labels convenient to your practice. The choices available are: 123 (factory set), RYB, RST, PQR, ABC. The factory setting is 1, 2, 3.

Table 6.2: Phase Labels (Programmable through Setup)
Factory Default = 1 2 3

1	2	3
R	Y	B
P	Q	R
R	S	T
A	B	C

7.7.Connection Diagrams

Choose the diagram below that best describes your application. You must ensure that the CT phase and corresponding PT phase are identical and that the CT polarity is correct as explained in “[CT Polarity](#)” above. Follow the outlined procedure to verify correct connection.

7.7.1.EM 6400 Rear Panel

The meter terminals are located on the rear panel. 14 terminals are provided, 7 terminals on each side:

- Six terminals for current, one “in” and one “out” per phase,
- Four terminals for voltage, for three phases and neutral
- Two terminals for meter auxiliary power supply and
- Two terminals for the RS 485 communications port.

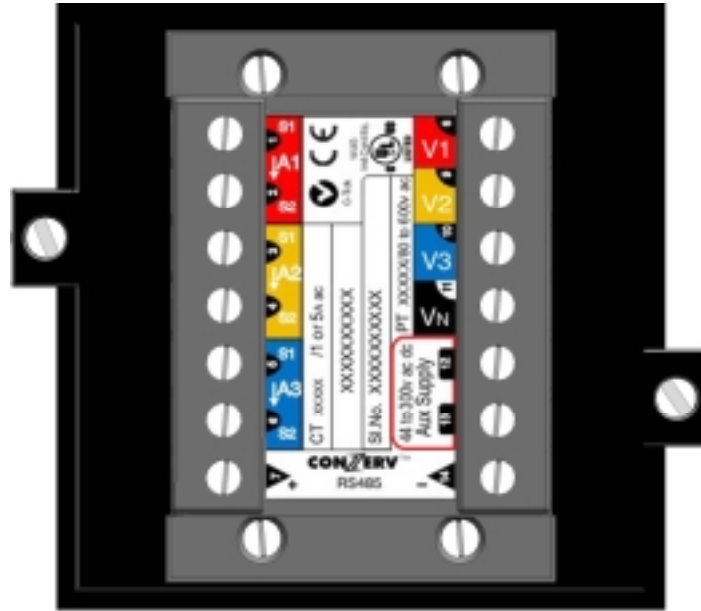

Figure 6.1: Meter Rear panel

7.7.2. Three Phase 3 Wire Delta

With 2 CTs. Direct voltage connections if the input voltage L-L is less than 601V ac. Otherwise, 3 PTs for Closed Delta or 2 PTs for Open Delta.

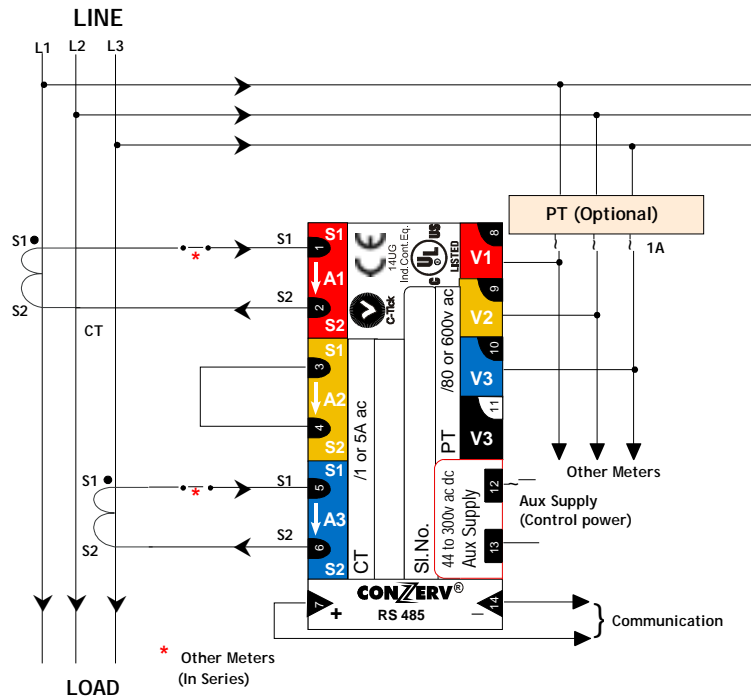

Figure 6.2: The Delta Connection Diagram

Note: Remember to make sure Delta is programmed in the meter PROG menu. Leave the Vn terminal un-connected.

7.7.3. Three Phase 4 Wire Star (Wye)

3 CTs. Direct Voltage Connections if the input voltage L-L is less than 601V ac. Otherwise 3 PTs.

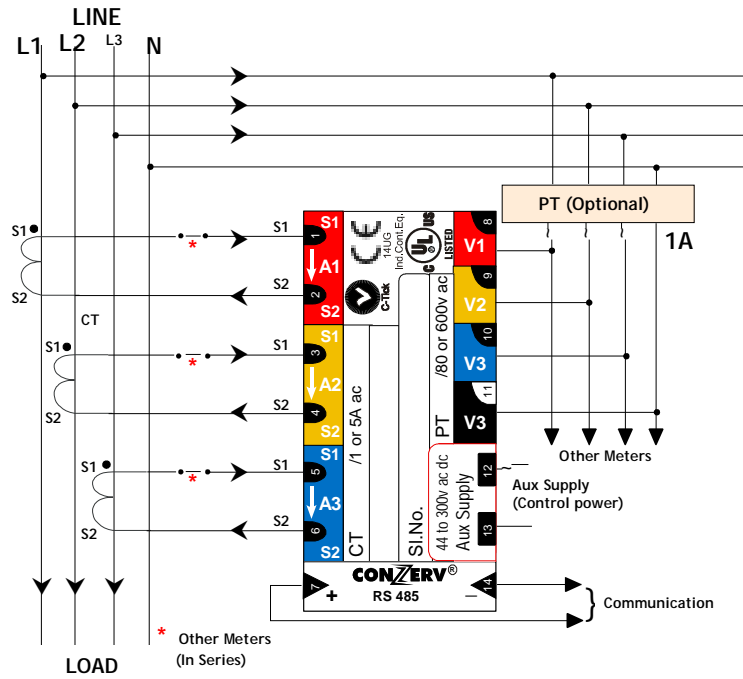

Figure 6.3: The Star (Wye) 3phase 4wire Connection

7.7.4. Single phase connection

Direct Voltage Connections if Voltages are less than 601V ac L-L. Otherwise use one PT. The unused current terminals must be shorted together.

- 1.) Program the meter in for STAR mode.
However Voltage primary and secondary needs to be programmed as Line to Line.
- 2.) Connect the voltage and current inputs only to the V1 and A1 voltage and current terminals of the meter.
- 3.) The unused current terminals (A2 and A3) must be shorted together to reduce noise picked up in the meter.
- 4.) However, the energy parameter readings will be accurate.

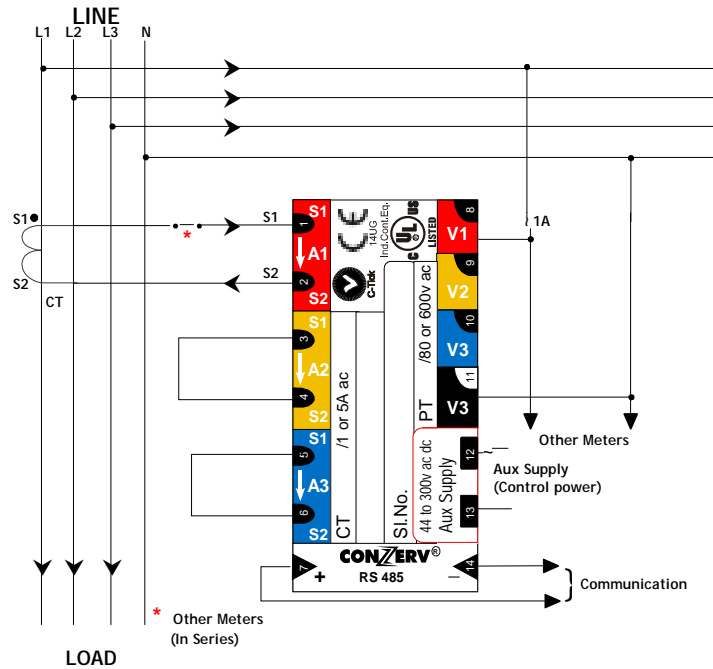

Figure 6.4: Single phase connection

8.COMMUNICATION INSTALLATION

8.1.RS-485

Each EM 6400 series instruments have a unique address up to three digits long. The range of the instrument address is 1 to 247. This allows the user to communicate with up to 247 instruments on one COM port of the PC. The EM 6400 series works on the Modbus RTU protocol. Under Modbus, each port supports up to 247 instruments. However, each RS485 segment allows only 32 nodes (instruments). Therefore, Data Repeaters are necessary to amplify the signal between segments.

Available standard baud rates are 1200, 2400, 4800, 9600 and 19200. To select the proper baud rate, apply the following rules:

- For best results under normal conditions, leave the meter factory-set at 9600 baud.
- For a smaller number of instruments over a long distance, use a low baud rate 4800 / 2400 / 1200.
- In noisy EMI, RFI conditions, try 4800 or 2400 baud.
- With short cable runs (< 300 meters or 975 feet), 19200 baud speeds up data transfers.

The connection diagrams show one Termination Resistor (RT) across the cable-pair at each end of the cable. This is a 1W resistor, 5% or better. Its value should approximately equal the Impedance of the Data Cable, as specified by the cable manufacturer. If you're not sure, a value of 120Ω might just work fine.

The termination resistors help absorb the data signal reflections off the ends of the cable, reducing data packet defects and the corresponding data packet re-transmissions. In cable runs longer than say 200 meters (650 feet), and with baud rates higher than 9600 baud, these benefits become more apparent.

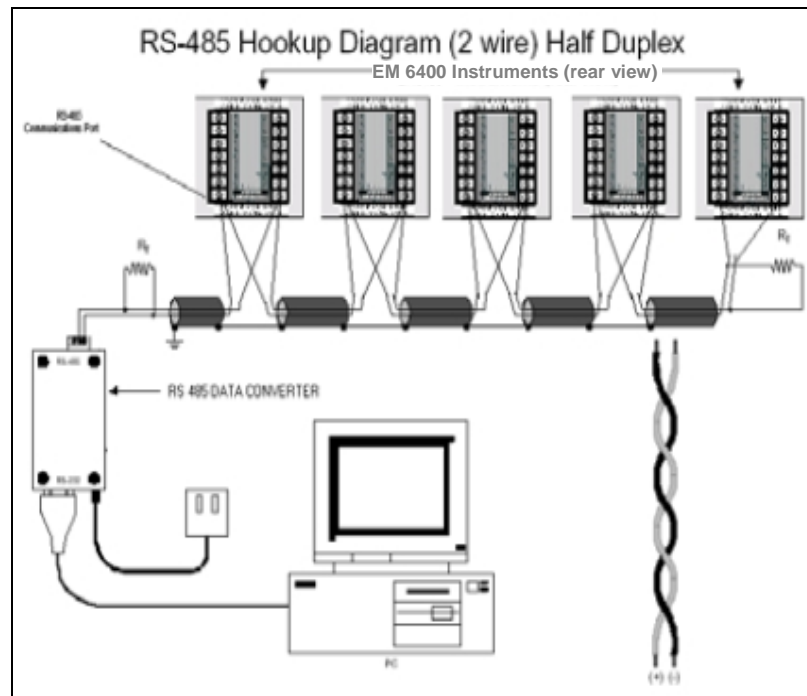

Figure 7.1: 2 Wire Half Duplex Communication Connection

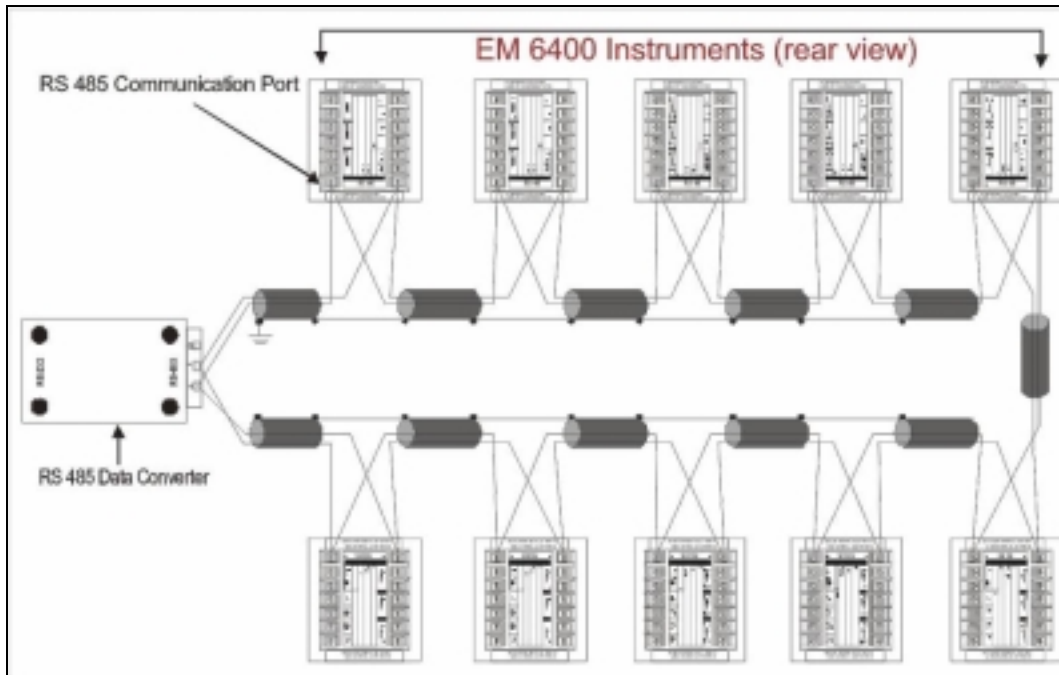

Figure 7.2:- Closed Loop, 2 Wire Half Duplex

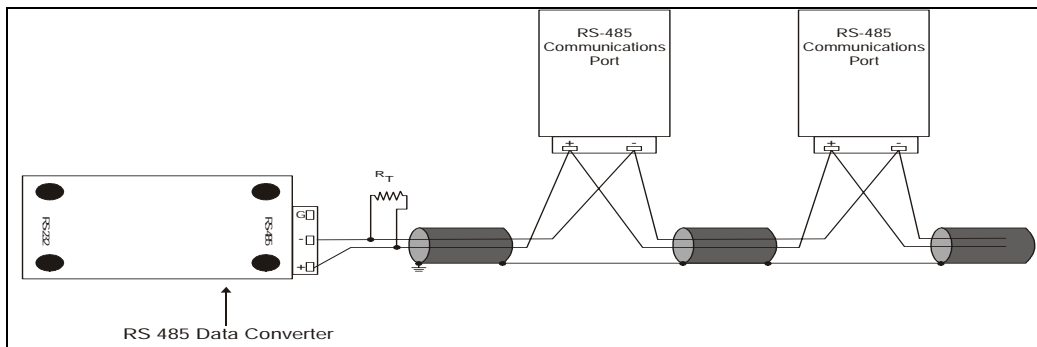

Figure 7.3: Detail of Closed Loop, 2 Wire Half Duplex

8.2.Repeaters

RS-485 transceivers (repeaters) of the half-duplex variety are required for large networks of instruments.

- In a two-wire connection, a maximum of 247 instruments on one COM port of the PC can be included in the same network.
- One RS 485 segment can accommodate only 32 devices.

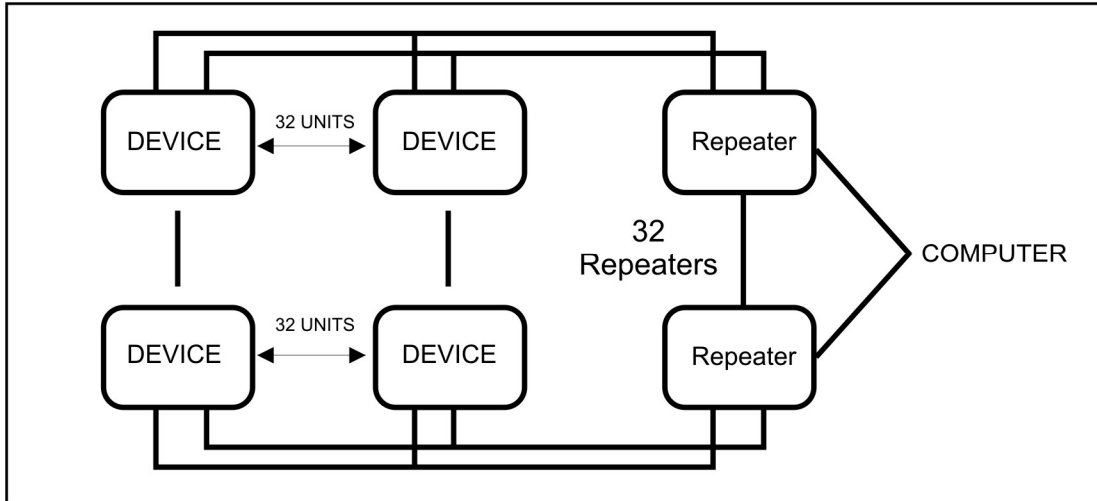

Fig.7.4: Two-Wire RS-485 Communication Installation Connection with Repeaters

8.3.Factory Settings

- Communication Protocol: Modbus – RTU
 - Baud rate: 9600 bps
 - Data bits: 8
 - Stop bits: 1
 - Parity: Even
- Data type: 32-bit float (real) for all parameters unless otherwise specified.
 - Except for parameter:
 - INTR (number of interruptions (Outages) in RMS parameter blocks) – unsigned 32-bit integer data type.
 - RunSec (run seconds in integrated block) – unsigned 32-bit integer data type.
- Data Format: Direct reading from the meter, no scaling is required.
- Modbus Function code: 03 (Read)

8.4.Modbus Registers

- Before integrating the meters into your SCADA network, your SCADA software must be configured for Modbus RTU communication, for the Address Blocks below, **by a qualified technician who understands your SCADA software**. Typically, the Device Address, Block Start Address, number of registers (20 registers per EM 6400 data block of 10 x 32 bit values), must be configured to suit the meter. Additionally, related SCADA settings for polling priority, logging and viewing the data must also be made. Refer your SCADA software instructions on how to do this.
- Serial data from the meter is available via the Modbus RTU protocol on the serial RS485 port. The Unit ID, which is unique to each meter, is programmed via the PROG Menu through the front panel keys.
- All addresses are in decimal. However, check your SCADA program's Modbus driver specs such as an offset of 40,001. In this case of EM6400, Address 3000 must be treated as Modbus Register Address 43,001.
- The EM 6400 supports the transfer of whole block and also of individual Data values (2 registers are used for storing single data value)
 - In transfer of whole block, it basically treats each block as an object with the starting address (e.g. 3000) considered as the object name. This enables fast block-transfers, since

energy management usually requires a block of related readings as of the same point of time. This method also eliminates time-skew within readings of that block.

- In transfer of individual data values, it basically treats 2 registers as an object with the starting address (e.g. 3900) considered as the object name. This enables to transfer required data values for energy management.
- Most of the data are in 32bit format (IEEE Single Precision Float). 2 registers are used for storing a single data value. A float (or real) setting on your SCADA Driver will usually suffice for automatic conversion. A few values are in unsigned long (32 bits).
- Your SCADA software must support Register Blocks consisting of different Data Types (Integers and Floats) to transfer of Whole Block.
- Each Modbus register size is 16-bits. All EM 6400 readings are 32 bits. Therefore, each EM 6400 reading occupies TWO consecutive Modbus Registers.
- Most advanced SCADA packages will provide these capabilities.

8.4.1.Parameters not available on Display

Voltage phase angle parameters are not available on the front panel display but available on the RS485 communication port:

S.No.	Parameters not available on Front Panel Display
1.	Voltage Phase Angle Phase – 1
2.	Voltage Phase Angle phase – 2
3.	Voltage Phase Angle Phase – 3

9.Appendix

Product Version	
Running	Obsolete
EM 6436 - v03.02.12	EM 6436 - v03.02.02 & v03.02.11

Refer the below modelwise

Note: The difference in EM 6436 v03.02.12 & v03.02.02 is the new features frequency “F” and Run hours added.

Table 9.1

Parameter		EM 6436 – v03.02.12 & v03.02.11	EM 6436 – v03.02.02	
RMS	V LL VLN V12 V21 V31 V1 V2 V3	•	•	
	A A1 A2 A3	•	•	
	F	•		
	%L - Amps			
	%Unbal - Amps			
	PF PF1 PF2 PF3	•	•	
	%A FS Analog colour coded load bar	•	•	
	RPM			
	A ⁰ Phase Angle A ⁰ 1 A ⁰ 2 A ⁰ 3			
	W W1 W2 W3	•	•	
	VA VA1 VA2 VA3			
	VAR VAR1 VAR2 VAR3			
	THD	V%1 V%2 V%3		
		A%1 A%2 A%3		
DM	Demand W or VA			
	Rising demand			
	Time remaining			
	MD Maximum demand			
	Hr MD occurred			
INTG	Wh	•	•	
	VAh			
	VARh			
	-VARh			
	Run hours	•		
	ON hours			
	Interruptions			
INTG WITH I/E	Wh			
	VAh			
	VARh			
	-VARh			
	Run hours			
OLD	Wh	•	•	
	VAh			
	VARh			
	-VARh			
	Run hours	•		

10.Key Factor for Success

All Installation, wiring and periodic maintenance of the EM 6400 as well as its associated circuits involve high voltages and currents. While this document suggests several safety and reliability steps, it must be used in conjunction with the safety codes in force at your location. Failure to practice safe working procedures is likely to cause damage to the installation, severe injury and/or death. Only qualified personnel must perform all activities including handling of electrical circuits during Installation, wiring and periodic maintenance.

Neither CONZERV nor its agents may be held responsible for damage or death arising out of the wiring and / or PT, CT or other external circuits.

The covers of the EM 6400 should never be dismantled or opened. There are no user-serviceable parts inside. The EM 6400 contains high-precision components, which require special handling available only at authorized CONZERV service locations. High voltages are likely to be present inside even after the EM 6400 has been switched off. Opening the covers of the EM 6400 and/or any attempts to dismantle, service, repair or modify the unit by unauthorized persons may cause severe injury, will damage the unit and will also render CONZERV's warranty void.

S. No	Installation Steps		Recommended	Effects if not allowed
1.1	Unpacking		a.) Ensure that the packaging of your EM 6400 is not damaged.	a.) This will render CONZERV's warranty void
			b.) Ensure that the seal at the back of the meter is not tampered. Do not try to open / repair the meter.	b.) This will render CONZERV's warranty void
			c.) Do not remove the protective plastic cover of your new Meters until the time of installation. Preserve the packing material.	c.) You will need the packing material if the meter needs to be shipped to CONZERV for servicing or calibration.
2.1	Panel Component Selection	External CT	a.) The meter accepts up to 6A ac RMS per channel directly. Above that, a Current Transformer must be used to scale down the current.	a.) If the input current is greater than 6A, direct current connection could damage the instrument.
			b.) Use Instrument Class 1 or better CT's. These will have better accuracy compared to Protection Class CT's.	b.) Protection Class (10P10, etc.) CTs have poor accuracy and phase characteristics. If these CT's are used to feed the EM 6400 the accuracy of measurements might be poor.
			c.) Ensure that the CT Primary rating has been selected so that your normal load variation lies between 40% and 80% of its full scale.	c.) If the CT is over-rated, say if the load is always less than 10% of the CT Primary rating and accuracy suffers. If the CT is under-rated, then you may exceed its full-scale and burn out both the CT and the meter.

			d.) With Dual - Range CTs, select the best range for programming the EM 6400.	d.) For dual range CTs do not change the range of CTs without re-programming the EM 6400, as the EM 6400 will read erroneous values.
			e.) Program the selected CT ratio before you start measurements using EM 6400.	e.) If the CT ratio that you have selected is not programmed before using the meter, the readings may be wrong.
			f.) Load current of the circuit should be 40-80% of the CT rating	f.) CTs contribute more error when operated lower than 20% of their rating.
2.2	Panel Component Selection	External PT	a.) For input voltage above 600 V ac Line-Line an external PT connection is necessary.	a.) If the input voltage is greater than 600 V, direct voltage connection could damage the instrument
			b.) Use Instrument Class 1 or better PT's. These will have better accuracy compared to Protection Class PT's.	b.) Protection Class (10P10, etc.) PTs have poor accuracy and phase characteristics. If these PT's are used to feed the EM 6400 the accuracy of measurements might be poor.
			c.) Program the selected PT ratio before you start measurements using EM 6400.	c.) If the PT ratio that you have selected is not programmed before using the meter, the readings may be wrong.
2.3	Panel Component Selection	Connection Wires for CT	a.) The cable connection should be rated for 7.5A or greater and have a cross-sectional area of 16AWG minimum. Install the wiring for the current circuit at 600V ac insulation minimum.	a.) EM 6400 has input current rating between 50mA to 6A. Thus the cable used for connecting the external CT to the meter terminals should be rated for a minimum of 7.5A.
2.4	Panel Component Selection	Connection Wires for PT	a.) The cable required to terminate the voltage sense circuit should have an insulation rating greater than 600V ac and a current rating greater than 0.1A.	a.) EM 6400 has input voltage rating between 100v to 600v ac. Thus the cable used for connecting the external PT to the meter terminals should be rated for a minimum of 600V ac. If the cable selection is wrong this could cause damage to the instrument.
2.5	Panel Component Selection	Fuse	a.) Use a 1A fuse on each voltage input. MCB to Voltage terminals to protect against short circuit	a.) Safety of operation. Affect meter circuitry – voltage circuit may not function

			b.) Use external surge suppressors in the Auxiliary Supply Circuit.	b.) Transients, Surges, Voltage swells affect the components of the meter lead to malfunctioning (test severity is over and above the specified limits). External surge suppressors should be used in order to ensure proper operation when the voltage surges exceed the Auxiliary Supply limits.
			c.) Use fuse across auxiliary terminals – 500mA to protect against short circuit	c.) Affect meter circuitry – display goes off.
3.1	Programming Setup	CT ratio programming	a.) The CT Primary and Secondary values must be User Programmed before using the Meter according to the external circuitry connected to EM 6400.	a.) If the CT ratio is not programmed according to the circuit connected to the meter, the readings might be wrong.
3.2	Programming Setup	PT ratio programming	a.) The PT Primary and Secondary values must be User Programmed before using the Meter. The EM 6400 allows Field Programming of both PT Primary and Secondary voltages.	a.) If the PT ratio is not programmed according to the circuit connected to the meter, the readings might be wrong.
3.3	Programming Setup	Selection of System type	a.) For three phase four wire circuits, select the “STAR” mode. For three phase three wire circuits, select the “DELTA” mode. For single phase circuits, select “STAR” mode.	a.) If the system type (Star/Delta) is not programmed according to the external circuit, the readings might be wrong.
3.4	Programming Setup	Selection of %FS	a.) Select the full-scale load percentage setting as per your circuit.	a.) If you do not select the correct %FS, the load bar indication might not be correct.
4.1	Mounting	Panel cut-out, bezel, depth behind bezel	a.) Mechanical dimensions Panel cut-out dimensions are 92 x 92 mm Bezel dimensions are 96 x 96 mm Depth required behind the bezel is 80 mm	a.) If the panel dimensions are not maintained; you will not be able to mount your EM 6400 successfully.
4.2	Mounting	Panel Spacing	a.) The panel doors must be easily opened to provide easy access to the EM 6400 wiring for trouble-shooting.	a.) Sufficient spacing will allow ease during troubleshooting or change in wiring.

			b.) Allow clearance if the unit is going to swing out, as well as adequate slack in the wiring. Allow space for terminal blocks, CT shorting blocks, fuses, auxiliary contractors and other necessary components.	b.) Sufficient spacing will allow ease during troubleshooting or change in wiring.
4.3	Mounting	Mounting clamps	a.) Mounting clamps shall be tightened using screwdriver to ensure accurate mounting of the meter on the panel.	a.) If mounting clamps are not sufficiently tightened, the meter position may shift and terminals may come in contact with other instruments on the panel. This could result in erroneous readings, short circuit.
			b.) For the last few turns – alternate between the two clamps and tighten two turns each (i.e. Tighten 2 turns on one clamp and then 2 turns on the other and so on).	b.) If clamps are not alternately tightened, the meter might be mounted slanted on the panel.
			c.) Do not over-tighten.	c.) Over-tightening could result in breaking of the clamps.
4.4	Mounting	Air circulation and temperature	a.) The EM 6400 should be separated from other equipment and sufficient space must be provided all around for cooling air to rise vertically past the instrument.	a.) Lack of sufficient air for cooling, cooling temperature higher than the specified operating temperature may result in over-heating of your EM 6400.
			b.) The temperature of operation should lie within (-10°C to 60°C).	b.) If the operating temperature exceeds the specified range adjacent circuit/ instrument will fail and may affect the meter functionality.
			c.) The cooling air temperature must be below the specified operating temperature	c.) Sufficient cooling of the meter might not be possible.
4.5	Mounting	Dust free	a.) EM 6400 should be mounted in a panel that provides protection from dust, moisture, oil, corrosive vapours etc.	a.) Protection of meter.
5.1	Wiring	CT wiring connection polarity and sequence	a.) Before wiring, de-energize the CT secondary by shorting it via a shorting block.	a.) If you leave the CT terminals open even momentarily when primary current is flowing, this causes high voltages that will overheat and damage the secondary of the CT and the instruments as well.

			<p>b.) There are three pairs of Current Input terminals marked A1, A2 and A3. Each pair of input terminal is labelled as (S1, S2) and has an arrow indicating the direction of current flow.</p>	<p>b.) Failure to connect CTs properly results in inaccurate power readings.</p>
			<p>c.) For proper measurements, the phase identification as well as the polarity of the current signals must be correct.</p>	<p>c.) If your meter is not reading power properly, it is more than likely that the CT is incorrectly wired Or If one of the W readings is negative, that particular phase CT is reversed and must be corrected.</p>
			<p>d.) The Forward flow (Import by consumer) current direction must be into the S1 terminal and the exit from the S2 terminal.</p>	<p>d.) During the Export Mode, S1 and S2 connections should be reversed or meter should be with I/E to record both the Import/Export values.</p>
			<p>e.) CT Mounting direction in line with current flow</p>	<p>e.) Negative kW, improper energy registration due to CT reversal.</p>
			<p>f.) Rating of panel CT and meter CT programming must be same</p>	<p>f.) Variation in Current, Power and Energy</p>
			<p>g.) Short the unused current terminals (S1, S2) together.</p>	<p>g.) The noise picked up by the meter may increase if the unused current terminals are not shorted together.</p>
			<p>h.) Shorting links of the CT to be left opened when meter is in operating condition. Short the link during maintenance, service and wiring check.</p>	<p>h.) Shorting of links bypass the current inputs to the meter and measurement will not take place.</p>
			<p>i.) Do not install selector switch on current circuit.</p>	<p>i.) Selector switch will interrupt energy accumulation.</p>
5.2	Wiring	PT wiring connection polarity and sequence	<p>a.) Before wiring, de-energize the PT secondary by opening the circuit or removing the fuse.</p>	<p>a.) Change of wiring connections in Power-ON condition, may result in shock, fire hazards.</p>
			<p>b.) There are 4 Voltage input terminals marked V1, V2, V3 and Vn. For proper meter operation, the voltage connection must be maintained. The voltage must correspond to the correct terminal.</p>	<p>b.) Incorrect voltage connections might result in incorrect readings.</p>

			c.) For Delta connection, the Vn terminal should be left un-connected.	c.) Vn can be grounded or left unconnected
			d.) Use a 1A fuse on each voltage input.	d.) Safety of operation
			e.) Do not short the PT secondary.	e.) Shorting of PT secondary may cause Short circuit.
			f.) Do not install selector switch on voltage circuit.	f.) Selector switch will interrupt energy accumulation.
5.3	Wiring	Auxiliary supply	a.) The auxiliary supply voltage for EM 6400 should not exceed the rating marked on the label.	a.) If the auxiliary supply voltage for EM 6400 exceeds the marked rating on the label, the meter will be permanently damaged and CONZERV's warranty shall be void.
			b.) In order to ensure accurate readings of the time of occurrence of Maximum Demand (hr), power the auxiliary of EM 6400 with uninterrupted power supply.	b.) The "hr"(time of occurrence of Maximum Demand) is accumulated as long as the auxiliary of the meter is powered ON. If the power supply to the auxiliary is interrupted, hr will stop accumulating until the auxiliary is powered up again.
			c.) Use external surge suppressors in the Auxiliary Supply Circuit to ensure proper operation when the voltage surges exceed the Auxiliary Supply limits.	c.) High input voltage due to surges can cause damage the internal circuitry.
5.4	Wiring	Tools/equipment	a.) Use a power driver or a hand screwdriver for making wiring connections.	a.) Do not use POZIDRIV Tips.
			b.) Screw Head Diameter = 3.5mm, TIP Shaft Diameter <5mm	b.) Torque greater than 60 N-cm may strip the screw or break the Safety Cover.
			c.) Tightening Torque: (25 to 60) N-cm Loosening Torque: (55 to 60) N-cm Screw Travel: 6 mm less wire thickness	c.) Worn-out bits and insufficient hold-down pressure while tightening may cause the bit to ride on the screw head thus stripping and damaging it.

5.5	Wiring	Loosened screws / wiring connections	a.) No loose contact or over tightening of screws for the input voltage, current and auxiliary supply terminals.	a.) Loose wiring/open connections can cause spark, arcing across meter terminals and adjacent circuitry, affect meter functionality. Over tightening of screws leads to erosion of screw heads.
5.6	Wiring	Wiring Check	a.) Do a wiring check. For details on wiring, refer the product user manual and FAQ on our website www.PowerMeterStore.com	a.) Wrong wiring could result in erroneous readings.
6.1	Usage tips	EM 6400 with demand parameters	b.) If demand is being monitored/controlled in LT side - consider HT/LT transformer losses, cable loss, meter error, CT error etc., (in the upstream). Always keep 5% to 10% below the contract demand for best results.	b.) The demand between EB meter and CONZERV's meter may be different.
6.2	Usage tips	Integrated parameters	a.) Periodic clearance of integrated parameters (once in a two month).	a.) Loss of data when automatically reset due to overflow of Registers
7.1	Maintenance	Calibration	a.) Periodic Calibration once a year is recommended.	a.) Ensure accurate readings.
		Wiring	a.) Look for loose/disconnected live wires	a.) Loose contact may cause wrong readings, damage to the installation (burning of cables), short circuit, malfunctioning of meter

11.FAQ's

11.1.NOMENCLATURE

Parameter	Description
V12, V23, V31	Line to line Voltages
V1, V2, V3	per phase voltages
A1, A2, A3	per phase currents
V LL	Average of line to line voltages
PF1, PF2, PF3	Power factor for each phase
V LN	Average of line to neutral voltages
F	Frequency of the measurement circuit
L%1, L%2, L%3	Percentage of load per phase based on C.T. primary
A°1, A°2, A°3	Current phase angle per phase
unb	Percentage of unbalanced load of all three phase
RPM	Revolution per Minute (for DG application)
VA, W, VAR	3 phase power parameters total
VA1, VA2, VA3	Apparent power per phase
W1, W2, W3	Active power per phase
VAR1, VAR2, VAR3	Reactive power per phase
V%1, V%2, V%3	Voltage total harmonic distortion for each phase
A%1, A%2, A%3	Current total harmonic distortion for each phase
VA.d	VA demand
R.d	Rising demand
t.r	Time remaining
Md	Maximum demand
hr	On-hour at which the maximum demand has occurred
VAh	Volt – Ampere hours
Wh	Watt hours
VARh	VAR hours Inductive
-VARh	VAR hours Capacitive
run.h	Total hours the load was ON
R.VAh	Volt-Ampere hours (export)
R.Wh	Watt-hours (export)
R.VAR	VAR-hours inductive (export)
-R.VAR	VAR-hours capacitive (export)
R.run	The total hours the meter was run with reverse energy flow (export)
t.VAh	Total Volt-Ampere hours (Import + Export)
t.Wh	Net watt-hours (Import + Export)
t.VAR	Net VAR hours inductive (Import - Export)
-t.VAR	Net VAR hours capacitive (Import + Export)
t.run	Total hours the meter was run with current input signals
On.h	Total hours the meter was ON. Accumulates if auxiliary supply is present
Intr	Auxiliary interruption. Accumulates the auxiliary interruptions
Star, Dlta	System configurations
thd	Total Harmonic Distortion

11.2.INSTALLATION

1. What are the factory default settings of the meter and how change it?

If there is no instruction from the customer while ordering, meter will be dispatched with the following default settings

SET Parameter	Default value
SYS	StAR
V.PRI	415.0
V.SEC	415.0
A.PRI	100
A.SEC	5.000
LAbL	123
VA.Fn	3d
d.SEL	Auto (optional)
d.PAR	VA (optional)
d.Prđ	15.00 (optional)
bAUd	9600
Prty	Evn 1
Id	1.000
F.S ₀	100.0
O.F	Wh
POLE	4.000

2. How to enter the setup mode?

During power on, keep the TURBO key (Earlier called as Favourite key) pressed continuously till meter display SET. (Refer display chart in QSG)

3. What are the wiring configurations possible in DigitAN?

STAR 4V3A and DELTA 3V2A which are selectable through the setup.

4. What is the meaning of Star and Delta in the setup table?

STAR means for STAR 3E, 4V3A (means for 3 phase 4 wire applications) and DltA means for DELTA 3E, 3V2A (for 3phase 3 wire applications).
Star is also called Wye in some countries.

5. Can I use DigitAN for single phase applications?

Yes, Please follow the steps below:

1.) Program the meter in for STAR mode. However Voltage primary and secondary needs to be programmed as Line to Line.
2.) Connect the voltage and current inputs only to the V1 and A1 voltage and current terminals of the meter.
3.) Here VLL average will show 2/3 of line to neutral voltage, VLN average will show 1/3 of input voltage and the current will show 1/3 of the current value. Ignore these Average Voltage and current parameters. Refer only the V1, A1, W1, which are available at the right most page, which shows the per phase VLN, per phase A, per phase W etc.

6. How to check for wrong connections?

These steps are applicable for both Star and Delta systems.

<p>1.) If the current in any phase is reversed (instead of S1 to S2 the connection is S2 to S1), Active power of W1, W2, W3 shows negative. Reverse the current inputs of the phase, which shows the W negative.</p>
<p>2.) For checking the System (Star or Delta) for the sequence of connection Connect all the Voltages and Auxiliary supply. Connect the A1 and A3 currents. Switch ON the meter. If the System is STAR then A2 current and power parameter will be zero, else if the System is Delta then A2 current and power parameter will display some value.</p>
<p>3.) If the phase sequences between Voltage and Current terminals are not sequential, then meter shows erratic readings. Refer ampere degrees of each phase for correction</p>

7. When do I need to connect an external CT/PT?

External CT is required when the current to be measured is greater than 6A.

An external PT is required when voltage greater than 600V.

8. Is it possible to use DigitAN without CT application (i.e. load <5A in 415/440V applications 3 phase or single phase)?

Yes for input current upto 6A maximum, the DigitAN meter can be used without connecting an external CT.

9. What is the range for input current and voltage of DigitAN?

4 Voltage inputs (V1, V2, V3, Vn) 110 to 415VLL nominal (Range 80 to 600VLL)

Current: 20mA to 6A ac.

10. What is the range for auxiliary supply for DigitAN?

Auxiliary supply voltage range: 44 to 300V ac/dc.

11.3.DISPLAY INDICATIONS

1. How are KILO, MEGA and GIGA ranges shown?

Range	7 segment Display	“K” LED	“M” LED
0.000 to 9999	Number	OFF	OFF
10×10^3 to 9999×10^3	Number	ON	OFF
10×10^6 to 9999×10^6	Number	OFF	ON
10×10^9 to 9999×10^9	Number	ON	ON

2. How is Lead and Lag shown for the PF parameter?

Check the Minus LED (“-“ LED) to the left of the reading, between “K” LED and “M” LED.

Minus LED ON: PF is LEAD or

Minus LED OFF: PF is LAG

3. What are VARh and -VARh under the INTG page?

VARh shows Reactive Energy- Inductive.

-VARh shows Reactive Energy-Capacitive.

If you have the IE (Import Export) option, then

RVAR shows Reactive Energy-Inductive.

-RVAR shows Reactive Energy-Capacitive.

4. How do I know which is the parameter value currently displayed?

Press any one of the 5 keys once; meter will display the parameter name of the current page under display.

Or

If none of the keys are pressed and if the auto scroll is also not enabled, then the meter repeatedly displays the current page parameter name (2sec) and value (8sec).

Or

If the auto scroll is enabled, then the meter will display the current parameter name (1sec) and value (4sec) and moves to the next page. See the QSG for more details on auto scroll.

5. What is the purpose of LED's (12 nos) on the right side of the display?

These LED's are provided to indicate the total load %age with respect to the full scale, which is editable through setup. This is bar graph where Each LED indicates 10% of load, to find the total load count all glowing LED's in this bar graph and multiply the number of glowing LED's * 10

Load Percentage	Bar Graph Display
Less than 10%	No LED's will glow
Above 10% and less than 50%	Only Green LED's will glow
Above 50% and less than 90%	Green and Amber LED's will glow
Above 90% and less than 120%	Green, Amber and Red LED's will glow
120% and above	All the LED's will glow

6. Why 3 colours of LED in the bar graph?

This is similar to a vehicle speedometer,

If the **load is below 50%** it is safe, which is indicated by the **green LED's**.

Loads between 50% and 90% are acceptable. (The user should ensure that the load does not exceed this and hence it is indicated using **amber LED's**).

Load above 90% may exceed the sanctioned limit, which is dangerous and hence indicated using the red LED.

7. What are DAI 1 and DAI 2 under DAIG page?

DIA1

First 3 digits of 1st row display the unit id.

4th digit displays the status as given below.

r - Receiving the data.

t - Transmitting the data.

u - Wrong unit id.

o - Any one of the following error (parity, over run or framing error)

F – Wrong function which MODBUS does not supports.

A – Wrong address.

2nd row displays the baud rate of the communication.

3rd row displays parity and no of stop bits

DIA2 gives the information on the model no and the version no.

Also refer FAQ 3 in Section 11 (GENERAL) below for information on DIA1 to DIA7 pages.

11.4.SETUP

1. What is “PROG” page? How to edit the setup table and clear the integrator?

The steps to edit the set-up table and clear integrator are listed below:

1.) Enter into the HOME page (RMS). Press “UP” key once.
2.) Press the “LEFT” key once, CODE “Y” will be displayed.
3.) Enter the password 1000 to enter in the setup.
4.) See the EM 6400 QSG to edit the setup or to clear the Integrators.
5.) By pressing the TURBO key during the meter power-on it is possible to enter setup.

2. Can I restore the OLD parameter, while editing the setup?

Yes, two steps are explained below.

Partially edited set up parameter: While editing the parameter if you want to restore the old set up data press the “LEFT” key continuously up to the blinking the first digit then press the “LEFT” key once again it will resume the old setup data.

Or

Save changes Y/N: After completing the set up table edit, when you are coming out of the set up table if “Y” is selected then the set up will save the new changes else if “N” is selected set up will restore the values before entering the set up.

3. How to set CT and PT ratio?

Please refer the QSG.

4. Can I set my own password instead of 1000?

No. The password is always 1000, which is not editable.

5. What is LABEL in the setup table?

The user can set the label as 123, AbC, rSt, Pqr and ryb, depending on the country and the requirement. These labeling options are to satisfy the international standards or requirements. In India normally people use ryb. These are used for identifying the phasewise parameters.

Example: If 123 is selected as label, then the phase wise current will be displayed as A1, A2, A3.

6. Explain d.PrD?

D.PrD stands for Demand Period, which is selectable by the user. In EM 6400 demand period is selectable ranging from 5 to 30minutes, in steps of 5minutes.

7. What is I.d?

This is a unique address called unit id, which is required for identifying the meter while communicating through RS 485 port. Unit id is editable from 001 to 247 through the meter set up.

8. What does F.S⁰ stand for?

F.S⁰ allows the user to set required full scale in % of CT Primary. While setting up a new factory or commercial complexes usually higher rated current transformer is selected than present requirement keeping the future expansion in mind. I.e: CT primary rating may be much higher than the sanctioned load. This may be as high as 10 times the present load. For Ex if the CT ratio is 500/5A, but the sanctioned load is only 100A, meter will indicate just 20% (bar graph and % load) even if the load is 100A. User may not notice even if he is exceeding the sanctioned limit, which result in penalty from EB. With the programmable FS for the above condition the user can select the FS as 20% of CT primary (sanctioned load), so that the meter will show 100% when the load is 100A.

9. What does O.F represent?

O.F stands for the Overflow parameter, which is selectable through the set up. There are two options Wh (default) or VAh.

10. What does POLE mean?

This is required for calculating the generator RPM, user has to enter correct no of poles based on which the generator RPM is calculated.

11. What does Unbalance (Unb) mean?

This is a measure of unbalance between loads of 3phases.

12. What is Eun 1 in the setup table?

The 1st three letters shows the selected parity (Eun for even, odd for odd or no for no parity) and the last digit of the same row shows the selected stop bit of the communication.

13. What is 3d and Arithmetic in VA function and which is best under what conditions?

VA function display in the setup table	Formula	Other names	Which one?
3d (default)s	$kVA_{3D} = \sqrt{\sum W^2 + \sum VAR^2 + \sum D^2}$ where D = Distortion Power per IEEE 100	U, Apparent, Vectors	Best all round
Arth		Arithmetic, scalar	Good only under Low unbalance

14. How to terminate the setup table editing using TURBO (earlier called as FAVOURITE) key?

The TURBO key can be used for terminating from setup table editing mode as explained below.

Example: The current CT primary settings is 5000, and the user need to change it to 6000, the following steps alone can be used

1.) Press the Right key 5 will blink.
2.) Change to “6” by using UP or DOWN key and “6” is still blinking.
3.) Press the TURBO key, “6” stop blinking and sets the value as 6000.
4.) Save the value by pressing the left key.

Where as in earlier versions after editing the 1st digit, the user had to navigate up to the last digit of the row by using right key and terminates the editing.

15. Is it possible to reset all the set parameters at once?

No. The user can edit the set parameters one at a time by entering into the setup mode.

16. Is there any pre-set maximum time duration for storage of user set parameters?

No. Set parameters can be changed only by editing.

17. What happens in case of a power failure while editing the set up parameters?

The last saved values before interruption will be present. The meter display goes to RMS on restoration of power.

18. What happens if the set parameters are changed after the meter is connected to a load?

Meter continues measurement as per the new set-up values.

19. How to select the set-up parameter to be edited?

Refer QSG

20. Is AUTO SCROLL possible among the set parameter display pages?

No. AUTO SCROLL is not possible among set parameters.

11.5.SIM (simulation) MODE

1. What is SIM mode and why it is required?

Simulation mode is provided for the purpose of demonstration of the features of the meter and in exhibition displays. In this mode user can see the functioning of the meter without any input signals, meter shows fixed Frequency, voltage and current and 0.5PF. Power and Energy parameters calculated based on this V (240VLN), A (5000A) and PF (-0.5) are displayed.

2. How to enter into SIM mode for Demo?

Power up the meter with left key pressed, it will go to “SIM” page.

Now press the right key to enter into SIM RMS mode, further navigation is same as the normal mode.

3. How to come out of SIM mode?

Please follow the steps below:

1.) Move to the home page “RMS” by pressing the TURBO key (Earlier called as Favourite key) repeatedly (depends on the models, up to 16 times in supper set)
2.) Press “UP” key once to see “PROG”.
3.) Press the “LEFT” key to enter the PROG Menu. Meter displays code “Y”.
4.) Press the left key 4 times to enter the password (1000). Meter displays SIM.
5.) Press the down key until you reach the display page “RUN”.
6.) Press the right key to enter RUN mode.
7.) Then press the down key once to return to RMS. Meter is now in the normal (RUN) mode.

NOTE: The mode can be changed only through the PROG Menu. Switching off will not change the mode, since switching off is often used to show the incrementing “Number of Interruptions” in the Integrator.

4. How to confirm whether the meter is in SIM or RUN mode?

In the SIM mode, meter does not display the actual value. It always displays fixed unchanging values. Example: V= 415VLL, 240VLN, A=5000A, PF =-0.5, Frequency= 50Hz and the Power and Energy parameters are derived from this.

In the RUN (normal) mode meter displays the actual measured values based on the input signals.

5. Is it possible to edit set parameters in SIM mode? Will this affect the displayed values in SIM mode?

Yes the setup can be edited in SIM mode and the values displayed in SIM mode are updated as per the edited setup.

11.6.AUTO SCROLL

1. How to enable the autoscroll?

There are 3 modes of auto scroll.

<p>1.) Scrolling with in the level. Keep pressing the down key for at least 3 seconds, the parameter name will be scrolled within the level (Refer QSG) and when the key is released meter will display “Auto” for a moment, which means the auto scrolling is enabled.</p>
<p>2.) Scrolling within the page. Keep pressing the UP key for at least 3 seconds, the parameter name will be scrolled within the page and when the key is released meter will display “Auto” for a moment, which means the auto scrolling is enabled. Here also the auto scroll is similar to the earlier one (down key). But within the page.</p>
<p>3.) TURBO Parameters (Favourite pages earlier) auto scroll Keep pressing the TURBO key (Earlier called FAVOURITE key) for at least 3 seconds, the parameter name will be scrolled as per the FAVOURITE page sequence (ref QSG) and when the key is released “Auto” will be displayed for a moment, which means the auto scroll of the TURBO parameters is enabled. It will start scrolling through the all the TURBO parameters.</p>

2. **How to disable the auto scroll?**
Auto scroll can be disabled by pressing any one of the 5 keys or by interrupting the control power (auxiliary power).
3. **What is the time duration between the displays of two consecutive parameters in auto scroll?**
The time duration between parameter to parameter displays in the auto scroll is 5 seconds (Parameter name is displayed for 1 second + the corresponding value for 4 seconds).

11.7.TURBO PARAMETERS (FAVOURITE PAGES)

1. **What are TURBO parameters?**
TURBO parameters (earlier known as called as FAVOURITE parameters) are a list of commonly used pages, which are pre-set in EM6400, which can be accessed using the TURBO key (earlier called as FAVOURITE key) in the following sequence. RmS, 'VLL, A, PF' 'VLN, A, F' 'VA, W, VAR' 'VA, W, PF' 'PF1, PF2, PF3' 'V%1,V%2,V%3' 'A%1,A%2,A%3' 'VAd, Rd, Tr' 'Md.hr' VAh Wh R.VAh R.Wh t. VAh and t. Wh .
The BOLD parameters above are optional and are available only with selected models.
2. **What parameters can be viewed using the TURBO key in EM6400?**
Totally 16 pre-set pages are available (8 pages are optional and based on the models selected). Refer the FAQ 1 above for TURBO parameters in EM6400 model.
3. **What parameters can be viewed using the TURBO key in EM6434?**
Totally 6 pre-set pages namely RMS, 'VA, W, VAR' 'VA, W, PF' 'PF1, PF2, PF3' VAh and Wh.
4. **What parameters can be viewed using the TURBO key in EM 6459?**
RMS, 'VLL, A, PF' 'VLN, A, F'.
5. **What parameters can be viewed using the TURBO key in EM 6436?**
RMS, 'VLL, A, PF' 'VLN, A, F', 'A, W, PF', Wh and Run.h
6. **What parameters can be viewed using the TURBO key in EM 6433?**
RMS, 'A, W', Wh and Run.h
7. **How to enable TURBO (known as FAVOURITE earlier) auto scroll?**
Keep pressing the TURBO key for at least 3 seconds; the parameter name will be scrolled as per the FAVOURITE page sequence (ref QSG) as mentioned. Thereafter, when the key is released, "AUTO" will be displayed and auto scroll of the TURBO parameters is enabled.
8. **How to enter into Home page (RMS) if the user struck any where in the navigation (except setup and CLR mode)?**
Press the TURBO key continuously till it reaches the RMS page.
9. **Can I set my own TURBO parameters (known as FAVOURITE pages earlier)?**
No the TURBO parameters are pre-set for each model and cannot be defined by the user.

11.8.Default Display Page

1. **What is Default Display Page?**
Default Display Page means you can select any page as "User-set" display page. You can scroll to other display pages. The User-set page is displayed 2 minutes after manual scrolling was stopped by the user. Default Display Page is user selectable.
This feature is available in models EM 6436 & EM 6433.
2. **How to I lock?**
Go to the page you want to set as default page. Then press the RIGHT and LEFT key together. Meter displays "LOCK".

3. **How to I unlock?**
Once Display lock is active, press the RIGHT and LEFT key simultaneously to unlock the Key page. Meter displays “ULOC”.

11.9.INTEGRATORS

1. **Which parameter is responsible for Integrator reset?**

By default, the Integrators are reset when the value of Wh reaches the maximum allowable reading (Refer FAQ 2 below). However, the user can select VAh as the Overflow parameter by editing the SETUP

2. **When does the Integrator reset?**

Integrator reset (Overflow) is based on CT ratio* PT ratio, which is generally called as Power ratio. The following table shows the Power ratio and the corresponding maximum reading for Wh/VAh. If the user – selected parameter VAh or Wh (default) reaches the limit given below with respect to the corresponding power ratio, all the values stored in the integrator will reset to zero (clears to zero).

PT Ratio x CT Ratio	Max Reading Wh/VAh
1 to 1.999	9999K
2 to 1000.999	9999M
Greater than 1001	9999G

3. **When does the number of interruptions (Intr) accumulate?**

Number of interruption accumulates only with the Auxiliary interruption. If the meter Aux is connected to the UPS or if there is no power interruption then the no of interruption may be zero always.

4. **When does the Run.h accumulate?**

Run.h is a measurement of load (Amp) ON time. It starts accumulating, only if the Amp is greater than 30mA in any one of the phases. It does not accumulate when the Amp is less than 30mA, even if the voltage is present.

5. **When does the On.h accumulate?**

On.h just measures the total duration for which meter is on irrespective of the presence of input signals or not. If the Auxiliary supply is present On.h will begin to accumulate.

6. **Which model has the CT reversal: auto –correction?**

This feature is applicable in EM 6436 & EM 6433 for Energy Integration in Star (Wye) mode. In star (Wye) mode energy integration will be always in forward direction irrespective of the direction of current flow or sign of the per phase power reading.

7. **Under what conditions integrator (kVARh, kWh, kVARh and -kVARh) does not update?**

EM6400 has in built reverse lock. In star mode two or all the phases of current is connected in the reverse direction the integrator may not accumulate. In the delta mode if any one of the phase current is in the reverse direction then the integrator may not accumulate. In short, if the total power is negative, then the integrator (INTG) parameters do not accumulate.

Note: If both the import and export energy are to be measured, then choose the model with IE option.

8. **Does On.h reset with auxiliary power interruption?**

No. The count in On.h stops with auxiliary power interruption and continues from the previous value once power is restored.

9. **Are any integrated parameter values reset with power interruption?**

None of the integrated parameters reset during the power interruptions, except the VA.d and R.d . Intr gets incremented with each power interruption.

10. What happens to t.run when only voltage circuit is energized and no current through current circuit?

t.run works only on the current in the current circuit and hence is not incremented when there is no current in current circuit.

11. What happens when the Integrator is cleared?

When Integrator is cleared, both the INTG and md registers are cleared to zero. The data available in INTG registers is stored in Old register.

12. What happens when md is cleared?

When md is cleared only the data in md register is cleared. The INTG registers are unaffected if md is cleared.

13. Is it possible to reset Intr to zero by the user?

Intr is a count of the number of interruptions to the auxiliary supply and reset to zero whenever the integrators are cleared.

11.10.FEATURES

1. What are the various Models and Options available?

- EM 6400
- EM 6400 + Demand
- EM 6400 + IE
- EM 6400 + Demand + IE
- EM 6400 + THD

2. What is the difference in the Demand parameter between EM 3000 and EM6400?

3.

S.No	EM3000	EM6400
1	Demand interval is selectable in steps of 1 min (1 to 30 min)	Demand interval is selectable through setup in steps of 5 min (5, 10,15,20,25 and 30).
2	Sliding window (Auto), Fixed window (RTC, User) can be selected through setup table.	Auto (sliding window) / User (Fixed window) can be selected through setup table. RTC sync is not commonly used and is not available.
3	Demand can be calculated for VA or W parameter, which can be selected through the setup table.	Same as EM3000
4	When the Aux supply is OFF the demand starts from the corresponding data in Auto and RTC demand. User demand starts from zero.	When the meter Auxiliary supply is OFF the demand (both sliding and fixed) starts from zero.
5	Demand update is every 15seconds	Same as EM3000
6	Demand control is possible with EM 3460.	Only demand monitor is possible with EM 6400. Demand Control is not possible and No predictive demand.
7	Time of occurrence for the Maximum Demand is real time i.e. HH: MM:SS and DD: MM: YYYY.	The time of occurrence for the Maximum Demand is with respect to on hrs of the system, since there is no RTC.

8	<p>CLR Maximum Demand Maximum Demand in version 5 can be cleared from the front panel CLR key while viewing the demand (not in auto mode) independent of integrator. Even though integrator reset will clear Max demand, profile will be available, in which H1 and L1 of the demand can be referred. Auto reset is optional.</p>	<p>CLR the Maximum Demand : Maximum demand can be cleared independently through the CLR function in the setup mode. When the Integrator is cleared, Maximum Demand also clears. Because the time of occurrence is based on the On.h Auto reset option not available.</p>
---	---	--

4. Does EM 6400 have the IE option?

IE is an optional feature available with EM6400.

5. What is the difference between I/E feature of EM3000 and EM6400?

S.No	EM3000	EM6400
1	<p>Import and Export is based on the total power parameters i.e. If total W and VAR is in the export side, energy will accumulate in the export side. Example: $W_r=1200$, $W_y=-1200$, $W_b=1200$ then $W_t=1200$ $VAR_r=10$, $VAR_y=-8$, $VAR_b=-6$, $VAR_t=-4$ which lies in 4th quadrant. So energy will accumulate in the Import side.</p>	Same as EM3000
2	<p>Inductive and capacitive option is not available in EM3000 EM3000 doesn't have separate inductive and capacitive VARh. Only net VARh is available.</p>	<p>KVARh inductive total will be the addition of 1st and 3rd quadrant kVARh. KVARh capacitive will be addition of 2nd and 4th quadrant kVARh.</p>
3	<p>No separate run.h for Import and Export, only total (Import + Export) is available.</p>	<p>Separate run.h for the Import and Export, i.e. when the meter is in the import separate run.h is accumulated and when the meter is in the Export separate run.h will be accumulated. Total run.h is calculated by the addition of import run.h and export run.h.</p>
4	<p>Over range indication (-HI-) is not required for EM 3000, because if any of the overflow parameters, including VAh total crosses the overflow limit meter overflows.</p>	<p>If the meter Import VAh is 9998G and the Export VAh is 9998G, the total VAh will be 19996G. Even though eLAN will transmit the correct value, this is out of range for the display. So it will be displayed as -HI-. But this is an extreme condition, not found in practice.</p>

6. Does EM 6400 measures THD for V and A?

EM 6400 with THD measurements for V (V%1, V%2, V%3) and A (A%1, A%2, A%3) is an ordering option. Please specify clearly at the time of ordering if you require this feature. However, these are only INTRODUCTORY FEATURES.

7. How many parameters are there in THD block?

THD (Line to neutral) block has 6 parameters. THD per phase V and A
There are two pages for THD in the display.

V% gives the percentage of voltage (L-n) THD in V1, V2 and V3 phase
A% gives the percentage of current (L) THD in A1, A2 and A3 phase.

- 8. Does EM 6400 give the percentage of individual harmonics?**
No, individual harmonics are not measured in EM 6400. Only per phase V (V1, V2, V3) and A (A1, A2, A3) total harmonic distortion are available.
- 9. What is the unit of THD value displayed or how is the THD calculated?**
THD values displayed are in terms of percentage of rms value of the respective voltage and current phases. Not in terms of fundamental.
- 10. What does Maximum demand time mean?**
Maximum demand time indicates the on-hour of the meter at which the maximum demand had occurred.
To know the correct time of occurrence of maximum demand, it is important to connect uninterrupted power supply across auxiliary terminals.
- 11. Is it possible to reset all the stored values at once?**
Yes. Clearing the integrator allows the user to reset all the saved INTG parameters.
- 12. When are the Old values saved?**
Values from INTG are saved in Old register in case
 - Integrator is cleared (INTG Clear)
 - Overflow of Wh/VAh parameters
- 13. List the parameters whose old values get saved when INTG is cleared?**
The INTG values getting stored in Old are: Wh, VAh, VARh, -VARh.

11.11.COMMUNICATION

- 1. Can the meter be connected to the communication network?**
Yes. DigitAN can be connected to the network through RS485 port, which is an optional feature.
- 2. What is the communication protocol for DigitAN?**
Communication protocol is MODBUS RTU.
- 3. What is the meaning of Compatible Linear Map?**
The compatible linear map starts from address 3900. All the parameters available in this block can be read individually or as a block.
- 4. How many parameters can be read in the single query from the compatible block?**
The user can configure any number of parameters in between 1 and 50.
- 5. What will happen if any non available block is queried?**
If any other non available block is queried, meter will transmit zero.
- 6. Are all the parameters displayed by the meter available for communication?**
Yes, except the DAIG pages and the set up block.
- 7. Where can I get the Address Map?**
NOTE: All queries related to Address Map to be transferred to EMS Group at CONZERV. Or feel free to contact at Customer Help Desk.

11.12.GENERAL

1. How can we find the meter constant?

This is not applicable for EM 6000 series products.

Meter constant is just a relation between the blinking rate of the POP LED and energy consumption (display reading).

For Example: 1000 impulses/ kWh. Generally manufacturers provide POP LED which blink faster than the display / counter update and it is useful where the display is mechanical (impulse or stepper) counter.

But in case of EM 6400, meters displays instantaneous V, A and Power parameters along with energy parameters. Using this we can easily calculate the accuracy of any parameter. So there is no need of any POP LED and hence there is no meter constant.

An average of a minimum of 10 continuous display values needs to be taken for correct measurement of instantaneous parameters.

2. What is the benefit of instantaneous parameters over meter constant (POP)?

Generally, POP is provided to check the Accuracy of the meters with mechanical display. In this method approximately 400 pulses are counted and compared with respect to the reference meter pulse. Large number of pulses is required in this method to reduce the measurement error, i.e. 1/4th of accuracy. Higher the impulse / kWh, faster is the test. Mostly the tariff meters are with mechanical displays and the test benches at electricity boards do not have a very stable source. So the Electricity Board insists on the POP LED on every meter for the purpose of testing.

In the case of DigitAN, we can see the instantaneous parameter updating every second. This will directly show the accuracy of parameter and very useful for testing both at laboratory as well as in the field. Average of 10 display readings will give the correct accuracy. But using the POP is both time consuming and may not give the correct information under all the conditions.

Example: For meter constant 1600 (1600 pulses per kW):

At 100% load, measurement time for 400 pulse is $400/1600$ hours = 15minutes as against 5 to 10 seconds in the case of ELF.

At 25% load, measurement time for 400 pulse is = 60minutes as against 5 to 10 seconds in the case of ELF.

At field it is not possible to check the accuracy of meter using the POP.

3. What is the purpose of DIAG pages?

S.No	DIAG	Available in EM6400
1	Communication unit id	Available in DIAG1 – Row1. This row is used to display the communication status also.
2	Communication baud rate	Available in DIAG1 – Row2.
3	Communication parity and stop bit.	Available in DIAG1 – Row3.
4	Model no	Available in DIAG2 – Row1
5	Version no	Available in DIAG2 – Row2 and 3
6	Display scanning	Available in DIAG3 to test the LEDs
7	No of times blocks fails to read	Available in DIAG4 – Row1
8	No of times 1 st block failed to read	Available in DAIG4 – Row2
9	No of times 2 nd block failed to read	Available in DIAG4 – Row3
10	Check Sum	Available in DIAG5 – Row1
11	Time taken for parameter calculation from 756 ms to x	Available in DIAG5 – Row2
12	Time taken for navigation max -750 ms to y	Available in DIAG5 – Row3
13	Integrator Reset mode : 1 for manual clear. 2 for overflow according to the CT and PT ratio.	Available in DAIG6 – Row1.

	3 for Due to the internal error.	
14	If overflow due to which parameter: 1 for VAh forward. 2 for Wh forward. 3 for VARh inductive forward. 4 for VARh capacitive forward. 5 for VAh Reverse. 6 for Wh Reverse. 7 for VARh inductive Reverse. 8 for VARh capacitive Reverse.	Available in DAIG6 – Row2.
15	Value at which the overflow occurred.	Available in DAIG6 – Row3.
16	Element selected in the setup table.	Available in DAIG7 – Row1.
17	VA Arithmetic or 3D selected in the setup table	Available in DAIG7 – Row2.
18	Label selected in the setup table.	Available in DAIG7 – Row3.

DIAG 4 and 5 are for internal QA purpose.

4. Does this meter function when connected with other meters?

Yes DigitAN can be used along with other meters (Connect the input currents in series and input voltages in parallel with the other meters).

5. What does DIAG stand for?

DIAG stands for diagnostic pages. Refer FAQ 3 above for details contents of DIAG pages.

6. Can the user edit the values in the DIAG pages?

The values in DIAG pages cannot be edited by the user.

7. What are the climatic conditions under which EM6400 can function without any failure or error?

Temperature range for operation of DigitAN	– 10 to 60 °C, (14 to 140 °F)
Temperature range for storage of DigitAN	– 25 to 70 °C, (-13 to 158 °F)
Humidity	Below 5% to 95%, non-condensing

END OF DOCUMENT

Optimum Energy Products Ltd
#333 11979 40St. SE
Calgary, AB T2Z 4M3
Canada

Phone 403 256 3636
Toll free 877 766 5412
Fax 403 256 3431

www.PowerMeterStore.com